

P O R T F O L I O

ARCò - ARCHITETTURA & COOPERAZIONE

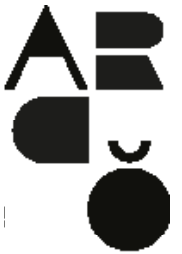

ARCò is a cooperative founded in 2008 by a group of architects and engineers dedicated to the production of sustainable architecture and landscape design.

Its projects are based on the constant pursuing of social, economical and environmental sustainability. For this reason, ARCò explores the local traditional techniques, in order to guarantee that the construction phase can be run independently by the communities involved. Moreover, ARCò consolidates the environmental side of each project by using natural or recycled materials, renewable energy sources, and by applying passive bioclimatic architecture principles. This approach has brought ARCò into the world of international cooperation, where it can use its skills to face and solve the different issues of humanitarian emergency.

ARCò's works have been featured on many publications and architectural journals, and have received international awards such as the Young Talents Renzo Piano Foundation Award and the Holcim Award for Sustainable Construction. The members of ARCò are also involved in teaching activities in different institutions, such as University of Pavia, Polytechnic of Milan, Nuova Accademia di Belle Arti (NABA), European Institute of Design (IED) in Turin and the S.O.S. School of Sustainability in Bologna.

ALBERTO ALCALDE (BARCELONA 1980) ARCHITECT, graduated in 2007 in the Universitat Politècnica de Catalunya. From 2002 on, he has worked in several architectural offices in Barcelona and Delft (Netherlands), dealing with projects of housing, public buildings, urban planning and landscape. He joined ARCò in 2009. Since then, he has coordinated on the ground the construction of the three schools and the re-movable clinic on the Occupied Palestinian Territory.

ALESSIO BATTISTELLA (ESTE 1971) ARCHITECT PH.D, member of Competence Board of Sos-School of Sustainability, focuses his work on landscape integration and systems of renewable energy production. He has been researcher and lecturer at DICAR (Department of Civil Engineering and Architecture) at the University of Pavia, and at the ABC (Department of Architecture, Built environment and Construction engineering) of the Polytechnic of Milan. He worked as consultant at RSE (Research System Energy) and as member of the Scientific Committee - Master Paesaggistaordinari – at NABA (New Academy of Fine Arts of Milan) / Polytechnic of Milan.

CARMINE CHIARELLI (BARI 1979) ENGINEER AND ARCHITECT, obtained his PhD in 2010 in Civil Engineering – Architecture in Pavia, with a thesis titled “Language and matter in the contemporary landscape,” exploring the relationship between metamorphosis of materials and architectural language’s construction. From 2006 to 2010, he carried out educational activities for the courses of Architecture and Architectural Design of CdL IEA University of Pavia. Since 2007, he has collaborated with several offices of architecture and engineering in Milan, Pavia and Taranto. From 2010, he has worked at the research laboratory of De Carlo Fixtures Spa, exploring the suppression of thermal bridges in laying joints.

VALERIO MARAZZI (MILAN 1979) ARCHITECT, graduated in 2004 in Milan Polytechnic with a thesis titled “Structure built with recycled and recovered materials”, researching alternative building techniques for sustainable architecture in developing countries. He focuses on the study of Feng Shui, permaculture and bioclimatic architecture, working and travelling around Europe, North of Africa and at Auroville Earth Institute in India. As a freelance designer, he collaborates with offices in Milan, Florence, Warsaw, and Porto Alegre.

DIEGO TORRIANI (MILAN 1980) ENGINEER. Obtained his PH.D in 2009 in Civil Engineering and Architecture in Pavia with a thesis titled “Potential Landscapes, reflections on the sustainability of the landscape“, issue which he has explored in numerous publications. He works as teacher, assistant and tutor in academic courses, seminars, and research centers, among which the IEA CdL of Pavia, Faculty of Architecture in Milan, IED Turin and the Institute for Construction Technologies of the CNR. Since 2008, he has worked as designer for E Plus Studio at Pavia, where he became partner in 2010.

LUCA TRABATTONI (LODI 1978) ARCHITECT. PH.D. in 2010 in Civil Engineering and Architecture in Pavia, with a research on the issue of public spaces in residential projects and a thesis titled “The Uncertain Living”. Since 2007, he has taught courses of architectural composition at CdL IEA in Pavia and in 2009 he became professor of Architectural Composition I. As a freelance designer, he has collaborated with several offices in Lodi, Milan and Pavia.

P R O J E C T S



KINDERGARTEN



UM AL NASSER VILLAGE, GAZA STRIP



2016



PROMOTER: VENTO DI TERRA NGO

DONOR: AICS (AGENZIA ITALIANA PER LA COOPERAZIONE ALLO SVILUPPO), TAVOLA VALDESE, CEI (CONFERENZA EPISCOPALE ITALIANA)



EDUCATION



250.000 €



COMPRESSED EARTH BLOCKS AND NUBIAN VAULT



WORK IN PROGRESS



The new proposal for the reconstruction of the school (destroyed during 2014 conflict) maintains the use of local materials while using a different constructive technique. It was in fact decided to build with earth blocks, pressed with a special machine that enhances the mechanical properties by using part of the debris in the area. The project is characterized by the Nubian Vault, a technique originally from the Nile valley, then widely diffused in Africa, as a culturally evocative element. The Nubian Vault technique is an ancient method of timberless construction and represents an innovative solution for the Gaza Strip, where the difficulty in finding supplies requires the use of local materials and low tech and low cost solutions.



INCLUSIVE TOWNS



HEBRON DISTRICT, PALESTINE



2016



CLIENT: MPDL (MOVIMIENTO POR LA PAZ)

DONORS: EUROPEAN UNION, JUNTA ANDALUCIA



SOCIAL



100.000 €



RECYCLED AND/OR NATURAL MATERIALS



REALIZED



The persistence of architectural and environmental barriers and the lack of an inclusive urban strategy represent some limits which contribute to the exclusion of PwDs. The theme of urban regeneration is envisaged through some little interventions which, as a whole, constitute an incisive and repeatable system. The projects were realized in four rural communities in Hebron District (Beit Ummar, Der Samit, Ithna e Saer). The projects include urban requalification of public spaces and architectural interventions in public building, such as clinics, municipalities, schools and community centres. We used recycled and natural materials which are easily accessible in situ. Well integrated with their urban context, the projects represent alternative and high quality solutions.



U.M.A. UNITA MONITORAGGIO AMBIENTALE (ENVIRONMENTAL MONITORING UNIT)



ITALIAN PAVILION, VENICE BIENNALE 2016



2016



CLIENT: LEGAMBIENTE



EXHIBITION



90.000 € (expected)

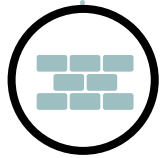

TRANSPORTABLE MODULE



WORK IN PROGRESS



THE SPICE UNIT



MONARAGALA, SRI LANKA



2015



CLIENT: ICEI

DONORS: ITALIAN MINISTRY OF FOREIGN AFFAIRS – ITALIAN CO-OPERATION, LOMBARDY REGION, MUNICIPALITY OF MILAN, CARIPLO FOUNDATION



PRODUCTION



-



COMPRESSED EARTH BLOCKS



WORK IN PROGRESS

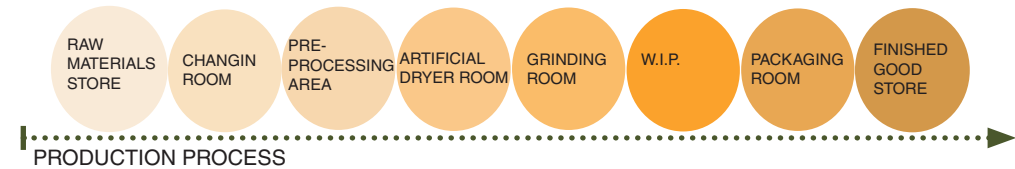

The spice unit is located in the village of Buttala in Monaragala district, in the south east of the island.

The building has been designed according to the production process of the spices, from drying to packaging. The result are two blocks: the smaller part is dedicated to the services and the larger part is the space for the production. The excessive rainfalls cause flooding and for this reason the factory has been elevated from the ground.

The perimetral and internal walls will be realized with compressed earth blocks. The surfaces of the inner walls will then be plastered in order to satisfy hygienical requirements. In front of the building, a water tower with two water tanks has been created, for services and production. A particular attention was dedicated to the natural ventilation, improved through the positioning of strategic openings in the upper part of the perimetral walls.

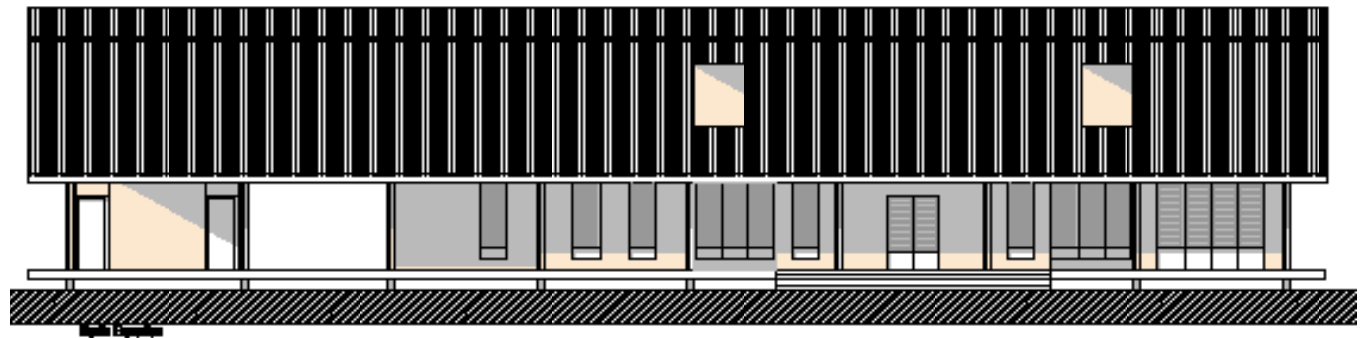
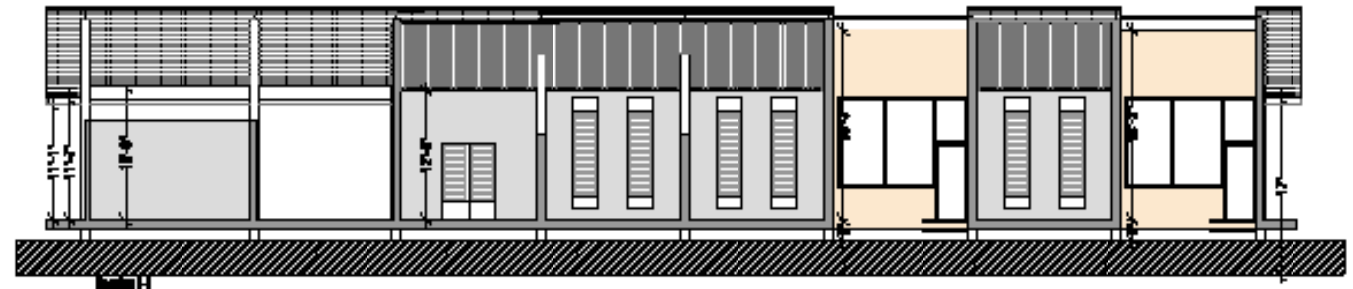

COFFE-BAR CALICANTUS



CASTELLO SFORZESCO, MILAN



2015



CLIENT: LUDESANA SRL UNIPERSONALE



CATERING



250.000 €

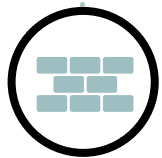

GALVANIZED STEEL AND GLASS



REALIZED



The new coffee bar in the court of the Sforza Castle in Milan fits in well with the architecture surrounding without competing with the historical pre-existence, but becomes a favorite point for its contemplation. The project begins after winning the municipal procurement contract.

The announcement presented clear and binding guidelines: use of noble materials, greatest possible transparency, absence of stable foundations and short realization time. The combined planning of ARCò and Ariano offices conceived a modular steel and glass building so that the standardization could facilitate the prefabrication in the workshop, and consequently minimize the building operation only in assembly the different elements.

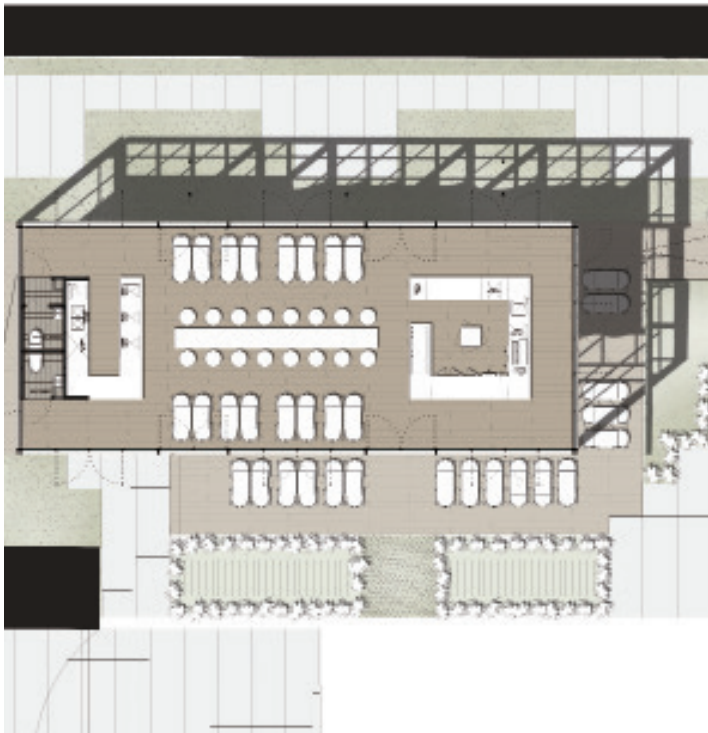

THE SUSTAINABILITY HUB



CASCINA CUCCAGNA, MILAN



2015



CLIENT: KFIELD COMUNICAZIONE SRL

SPONSOR: LAVAZZA, NOVAMONT



EXHIBITION



90.000 €



UNTREATED WOODEN CLADDING AND STRUCTURE



REALIZED



It is a structure entirely made of untreated wood designed to expose the cycle of compostable coffee pods produced by Novamont - Lavazza. The building is divided into two parts characterized by two different climates, the first greenhouse, which must contain the coffee plants, the second, colder, which must contain mushrooms produced by the coffee grounds. The set made of recycled cardboard is designed to host conferences on the theme of circular economy.

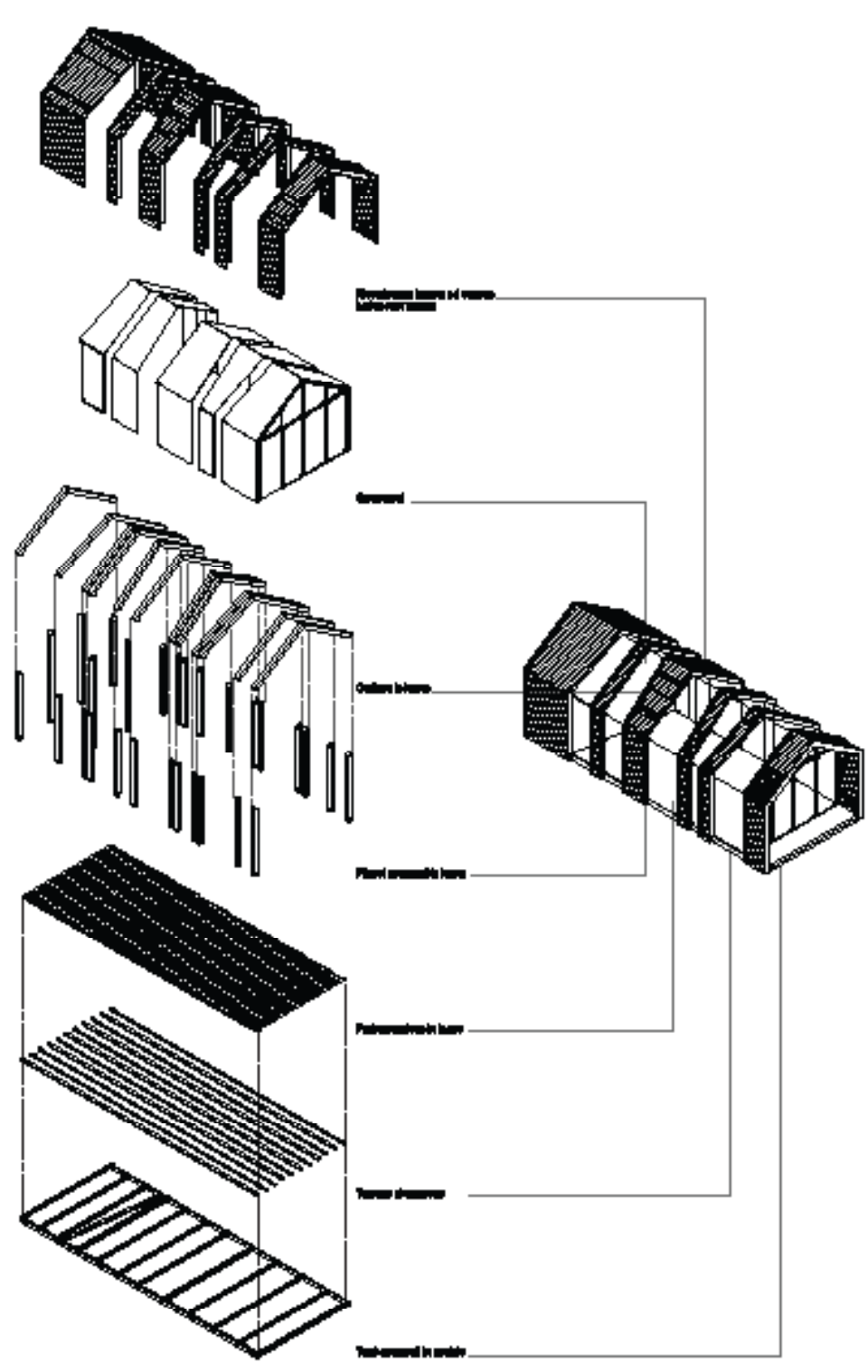

POLISH PAVILION



POLISH PAVILION, MILAN EXPO 2015



2015



CLIENT: FUTURA DESIGN STUDIO



EXHIBITION



5.000.000 €

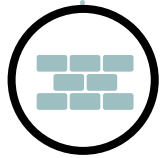

WOODEN BOX



REALIZED.
CONCEPT DESIGN: PIOTR MUSIALOWKY



The Pavilion has a simple, rectangular form whose external look is outlined by wooden boxes. The openwork structure refers to the ecological and simple form of apple boxes.

One of the attractions of the Pavilion is its magical garden, a Polish orchard, full of apple trees. The hidden garden becomes a place to relax and it is clearly associated with the Polish agriculture. Apples are one of Poland's top agricultural exports.

Visitors come to the garden through its center follow a narrow, winding path interspersed at irregular intervals by apple trees. The reflection of trees in the mirrors creates the illusion of a vast and infinite space, thus emphasizing the magical atmosphere of the space.

Another part of the exhibition is devoted to the regions, promoting them and the use of rural land. The path leads the visitor to a cinema, in which a set of videos promoting the economy and culture of Poland.

ARCò developed the definitive design as technical local partner in Italy.

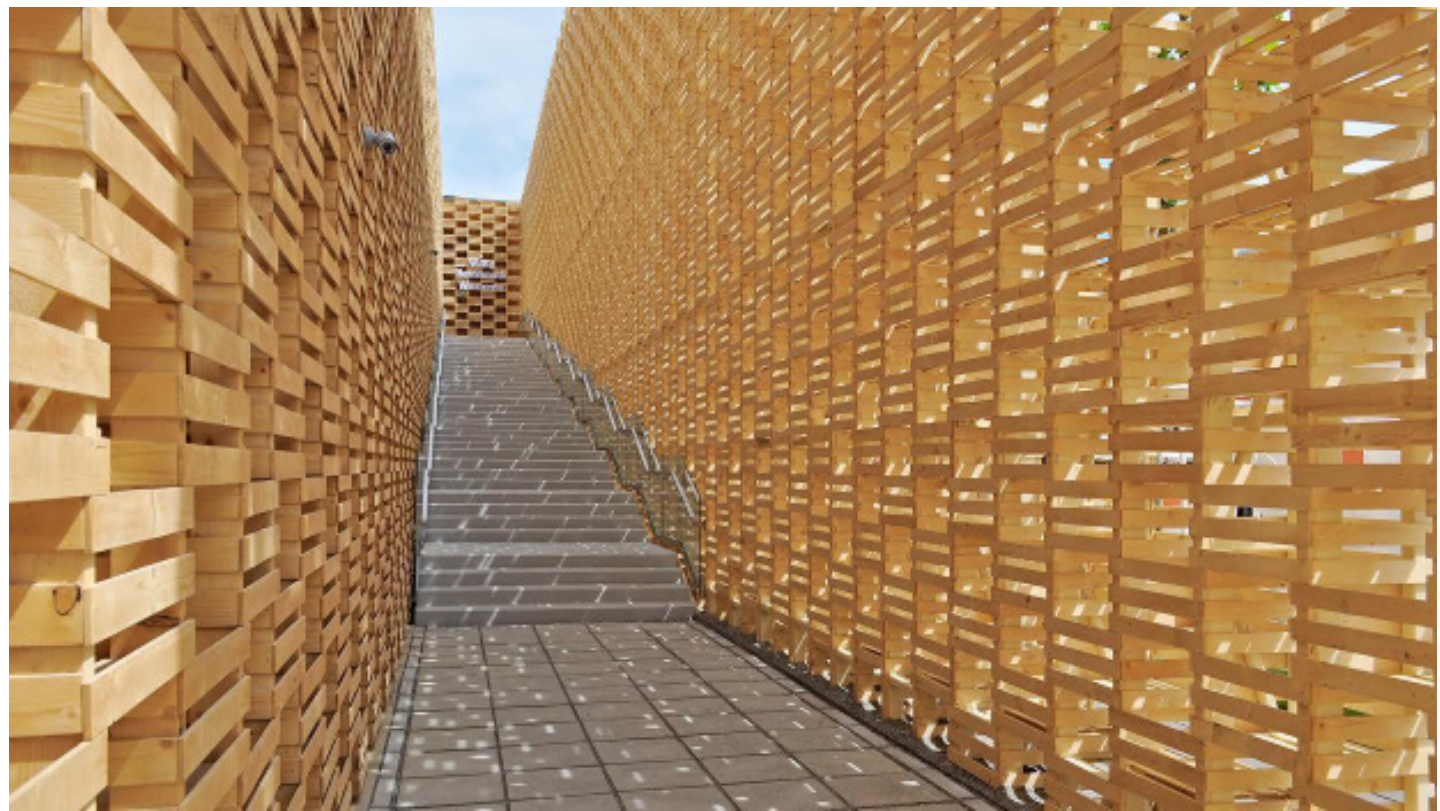

PRIMARY SCHOOL



AL JABAL, AREA C, WEST BANK



2015



PROMOTER: VENTO DI TERRA NGO

DONOR: UN OCHA (UNITED NATION OFFICE FOR THE COORDINATION OF HUMANITARIAN AFFAIRS) - ERF PROGRAMME



EDUCATION



142.000 €



STONE BOX GABIONS



REALIZED



The school in Al Jabal is the extreme synthesis of the re-use of local material. The idea to adopt the technique of gabions, generally used for retaining walls in landscape preservation areas, was born since the very first visits to the site. In fact, in this area there is an abundance of the local stone in its typical yellow ochre color. The first meetings with the local community also highlighted the added values of security and stability that this technique aroused in people. Speed of construction and aesthetic impact played as well a decisive role in the final design choices.

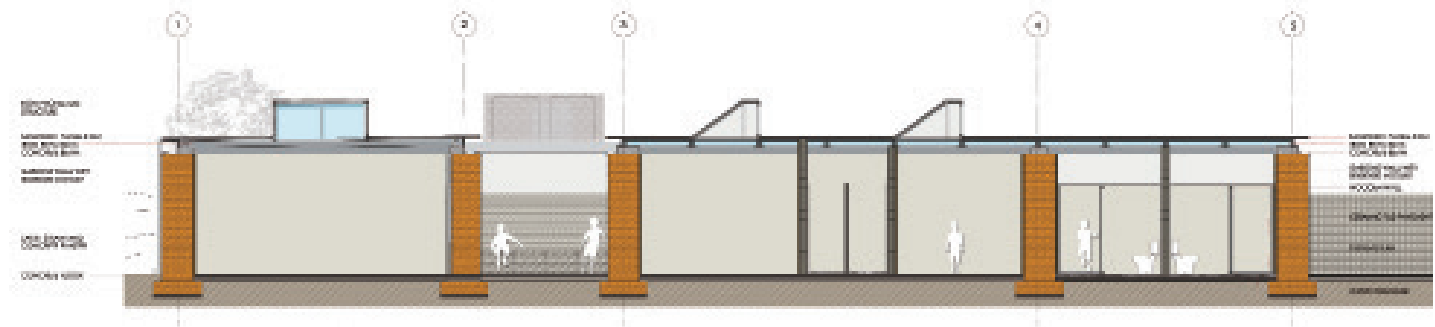
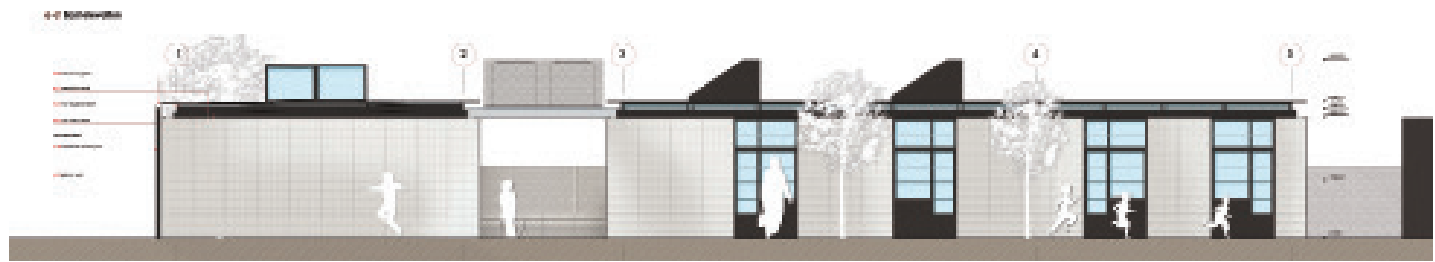

CUTTER BOARD
CUTTER CLAMP
ROCK L PROFILE TO CONNECT
BEAM AND IRON SHEETS
ROCK L CLAMP
ROCK SHEET 112
WATER PROTECTION
WIRE MESH 3mm
ROCK FINISH 2mm
ROCK WIRE
REINFORCEMENT

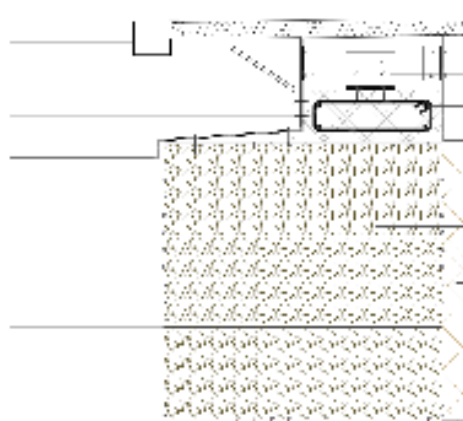

SANDWICH PANEL
ROCK ANGLE IRON BEAM
IRON L PROFILE TO FIX THE BEAM TO THE CONCRETE
O.C. IRON BARS AND O.C. STIRRUPS
CORNER L
IRON SHEET
STONES
A DETACHED IRON L PROFILE

SANDWICH PANEL
IRON L PROFILE TO CONNECT BEAM
AND IRON SHEETS
O.C. IRON BARS AND O.C. STIRRUPS
ROCK SHEET
STONES

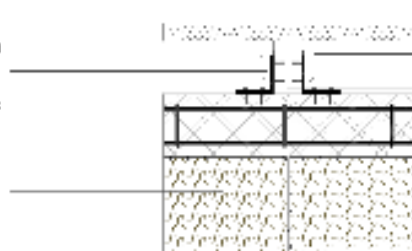

ROCK L PROFILE TO CONNECT
BEAM AND IRON SHEETS
ROCK ANGLE IRON BEAM
ROCK FINISH 2mm
ROCK WIRE
REINFORCEMENT



ORPHANAGE ELISA ANDREOLI



ORURO, BOLIVIA



2014



CLIENT: LA GOTITA NGO
DONOR: LA GOTITA NGO



ORPHENAGE



90.000 €

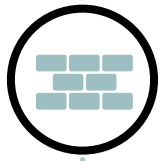

GREEN ROOF, GREENHOUSES



REALIZED



The pre-existent conditions of the big structure of the orphanage were critical, as the metal sheet roof covering it was totally inadequate at assuring thermal and acoustic insulation. Moreover, because of insufficient windows dimension, the amount of natural light entering the rooms was not suitable to the daily activities. This project creates a comfortable environment into the entire building through a whole rehabilitation of the roof. The new green roof will ensure the right level of thermal insulation. The skylights will provide the proper amount of light and will contribute to the heating of the rooms, thanks to the greenhouse effect on the corridors. This represents only the first phase of the design, that will comprehend also the installation of an heating system and the rehabilitation of the external spaces.

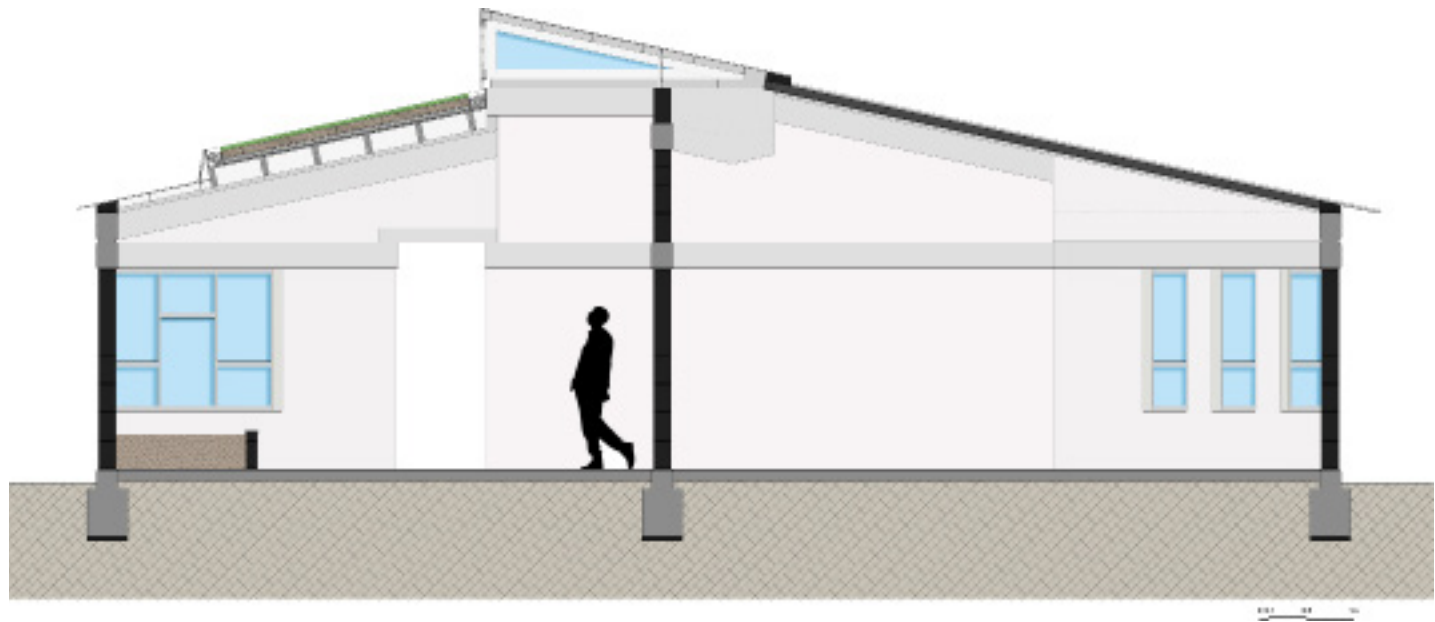

Existing roof

New roof with green and transparent band

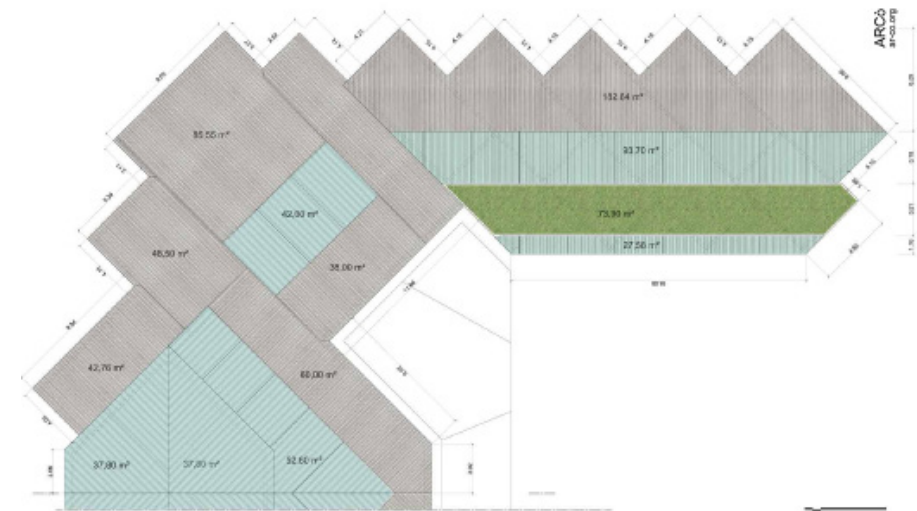

KITCHEN



UM AL NASSER VILLAGE, GAZA STRIP



2014 _ DEMOLISHED DURING THE WAR OF 2014



PROMOTER: VENTO DI TERRA NGO

DONOR: ITALIAN COOPERATION, CEI (CONFERENZA EPISCOPALE ITALIANA)



CATERING



60.000 €



EARTHBAGS



REALIZED



This project provided a new kitchen for the kindergarten of Um Al Nasser. The same construction technique was used for both the walls, made with earthbags, and the vaults, in steel with metallic external finishing and wooden internal. The project was completed in June 2014, right before the start of the clashes within the Gaza Strip, and was demolished by the Israeli military forces in July 2014, before having the opportunity to be exploited to its full potential.



PRIMARY SCHOOL



RAMADIN, QALKILYA GOVERNORATE, WEST BANK



2014



PROMOTER: VENTO DI TERRA NGO

DONOR: UNDP (UNITED NATIONS DEVELOPMENT PROGRAMME)



EDUCATION



85.000 €



PISE; MUD AND STRAW BRICKS



REALIZED



The rehabilitation of Ramadin primary school succeeded in giving a quality space for lessons to the community without going against the military laws that restrict new constructions in the area. The existing tents have been transformed in a proper school with simple steps: reinforcing the metal tubular structure; providing a solid basement; constructing insulating walls and roof; providing finishing. The work has been conducted in strong accordance with the local community and with a self-construction logic. Our strategy has been developed with the idea of maintaining the existing structures of the tents, that was simply adapted to the new spaces. Playing with the shadows of the strong desert sun, the new volumes draw indoor and outdoor spaces and paths.

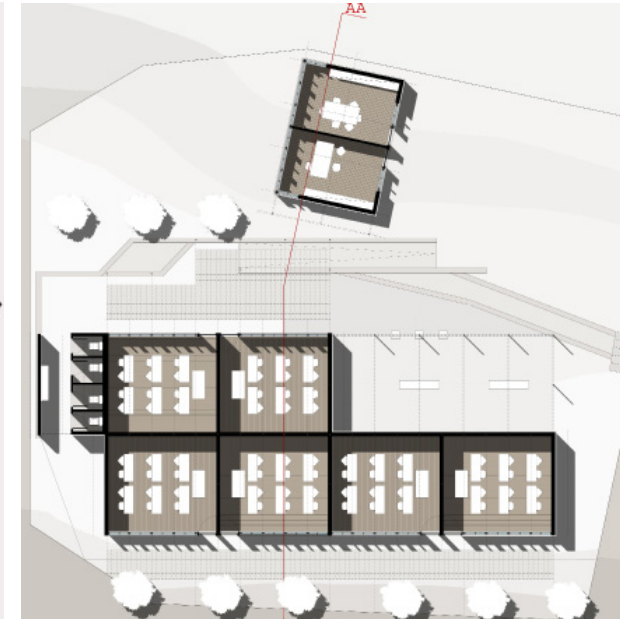
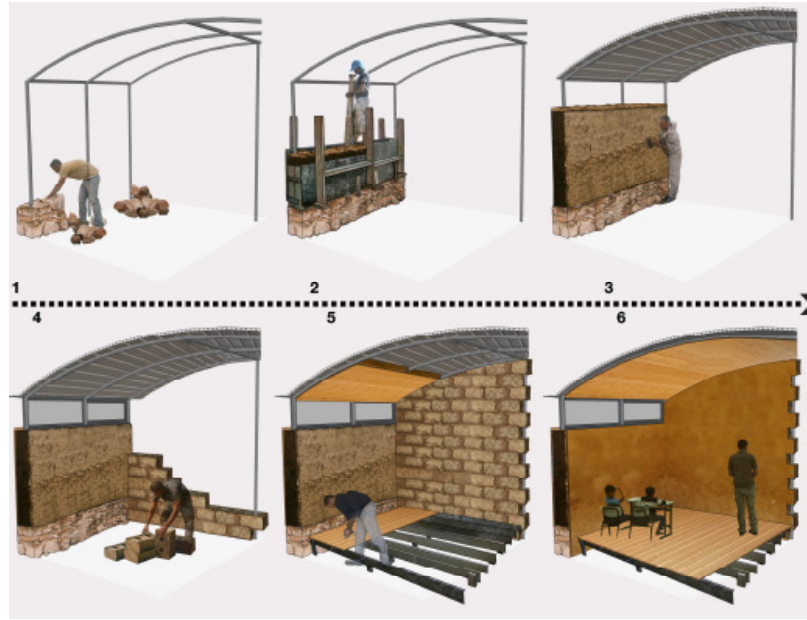
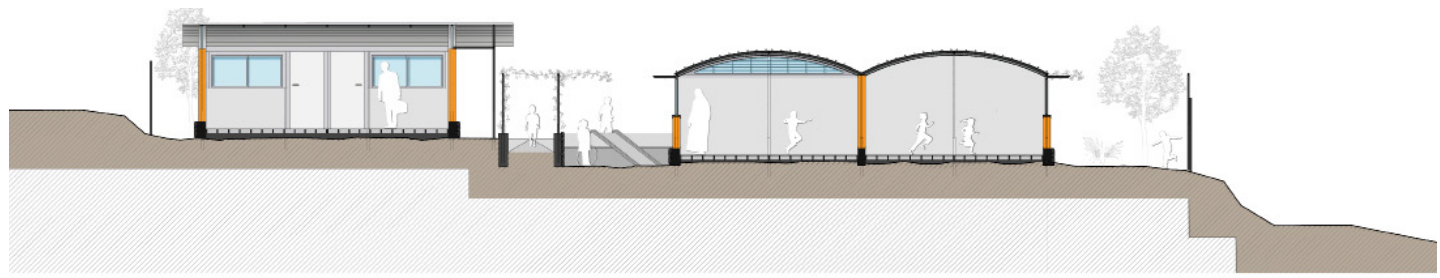

LOCAL MARKET



HERMEL, LEBANON



2013



CLIENT: PROVINCE OF TURIN + FPMCI + PDA



PRUDUCTIVE



-



MODULAR GREEN ARCHITECTURE



PROJECT

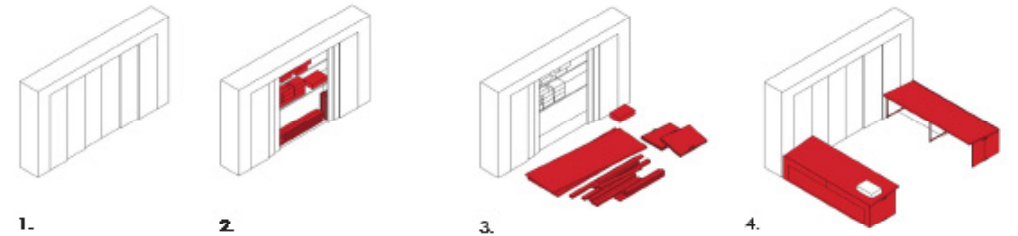
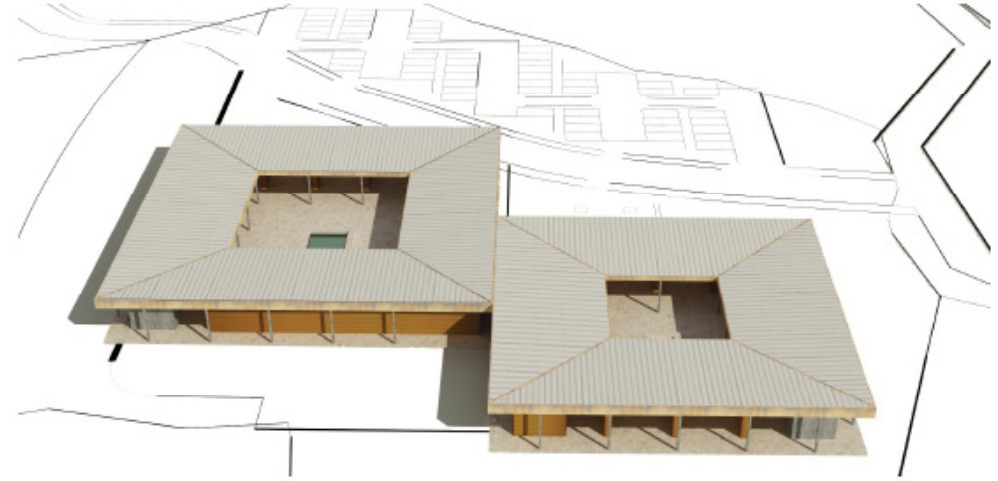

1.

2.

3.

4.

The project, funded by the European Union in the frame of the Development Program for the organization of the industrial and handicraft sector in Hermel, started from the idea of a modular solution, able to adapt itself to more functional needs.

The project takes inspiration from the memory of a caravanserai, the main historical reference for Arabic markets. It interprets the reference in a contemporary way, considering the particular needs of Hermel. The result is a shady open air public space, organized to host the wholesale activity.

The main principles displayed in this project are:

- functionality, flexibility and modularity;
- water collection, energy self sufficiency.

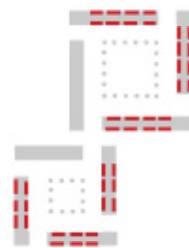
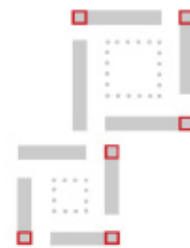
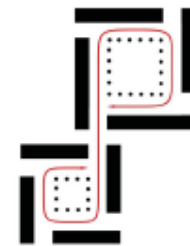
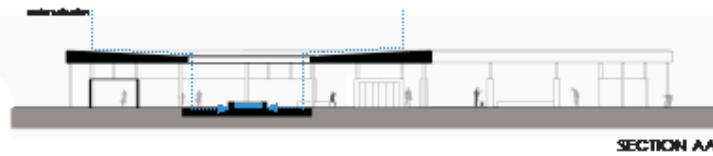
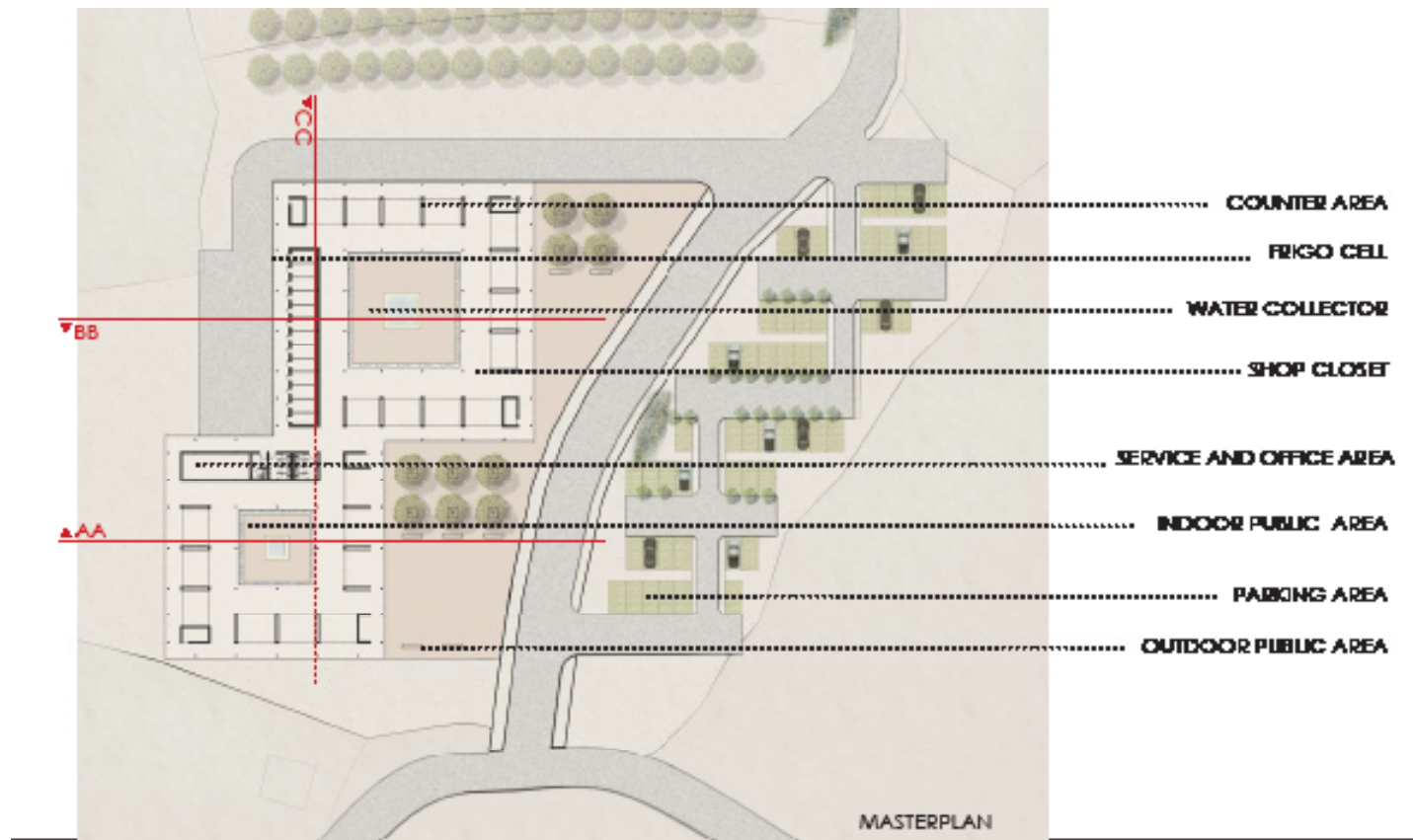

HANDICRAFTS AREA



HERMEL, LEBANON



2013



CLIENT: PROVINCE OF TURIN + FPMCI + PDA



PRUDUCTIVE



-



MODULAR GREEN ARCHITECTURE



PROJECT

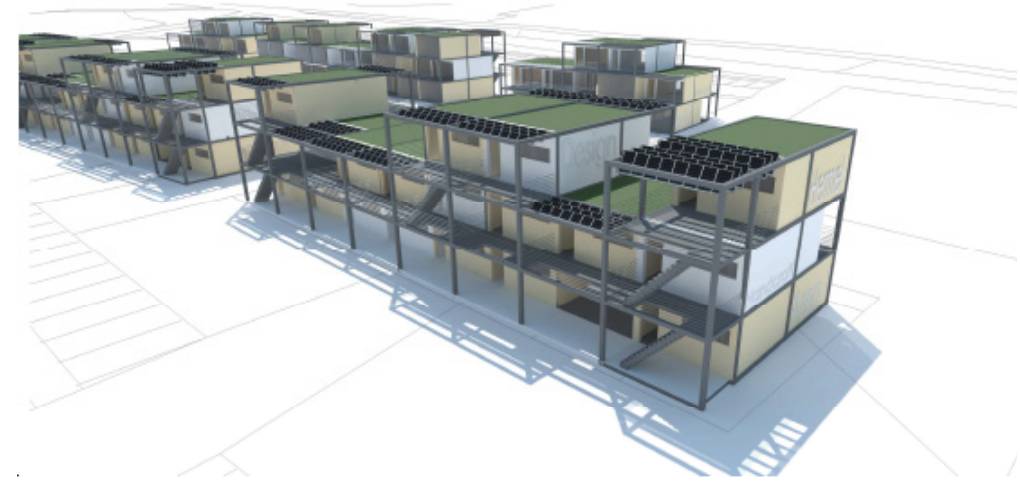

SHOWROOM & FACTORIES

- Tiles factory
- Car Sunrappage
- Furniture factory
- Kitchen factory
- workshops of the glass
- Vanisher auto shop
- Automobile bodyworker
- Automobile mechanic shop
- Mechanical shop for bicycles and cars

FACTORIES

- Tiles factory
- Aluminium factory
- Paper factory
- Joineries factory
- Vanisher factory
- Welding factory

SHOWROOM & SHOPS

- Complementary auto
- Graphic advertising studies
- Automobile auto shop
- Automobile retailer electrical shop

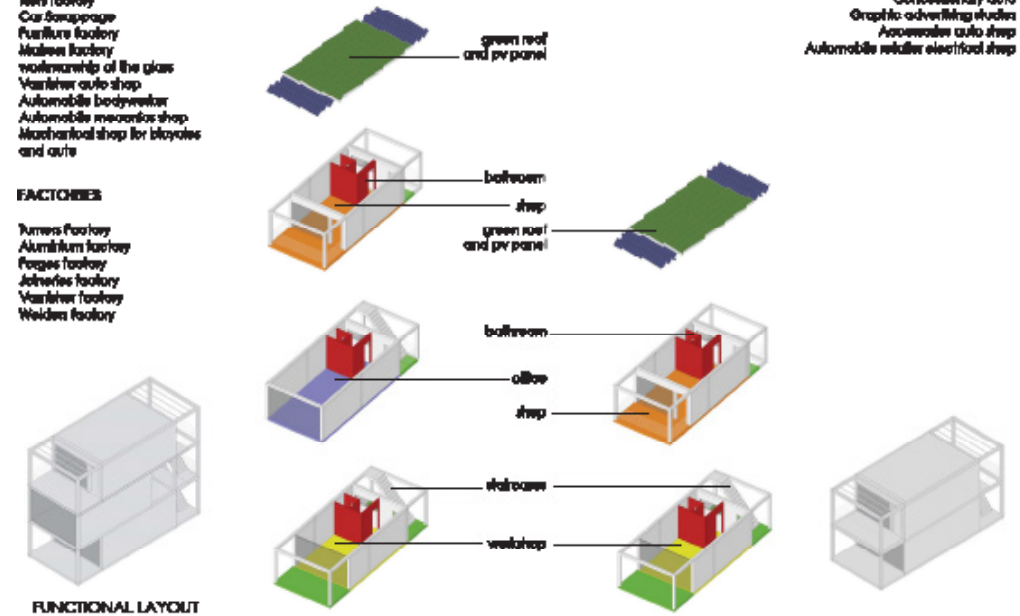

The project, funded by the European Union in the frame of the Development Program for the organization of the industrial and handicraft sector in Hermel, applies the idea of a modular solution, in view of future functional developments.

This approach is enriched by sustainable principles based on three main focuses:

- cheap, modular and standard structure;
- flexible interior spaces;
- insulation, cross ventilation and energy self sufficiency.

In this way one structure can generate many different buildings, that every user can eventually personalize. The modules aggregation produces a general master plan with private, collective and public spaces, services for the workers and parking places for customers.

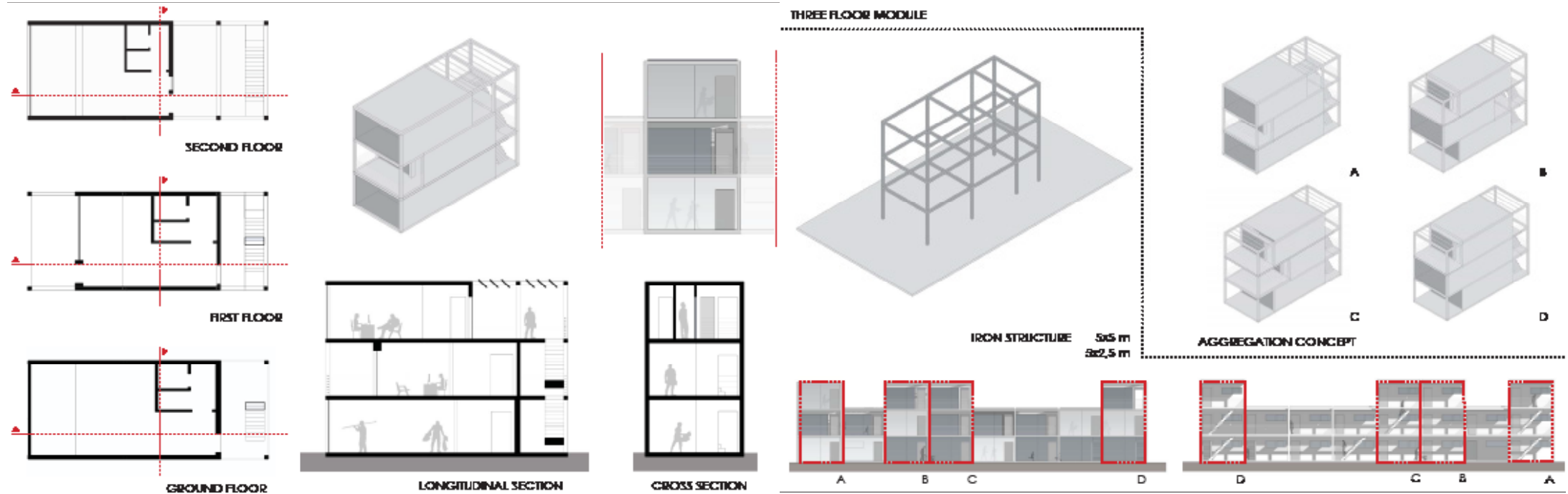
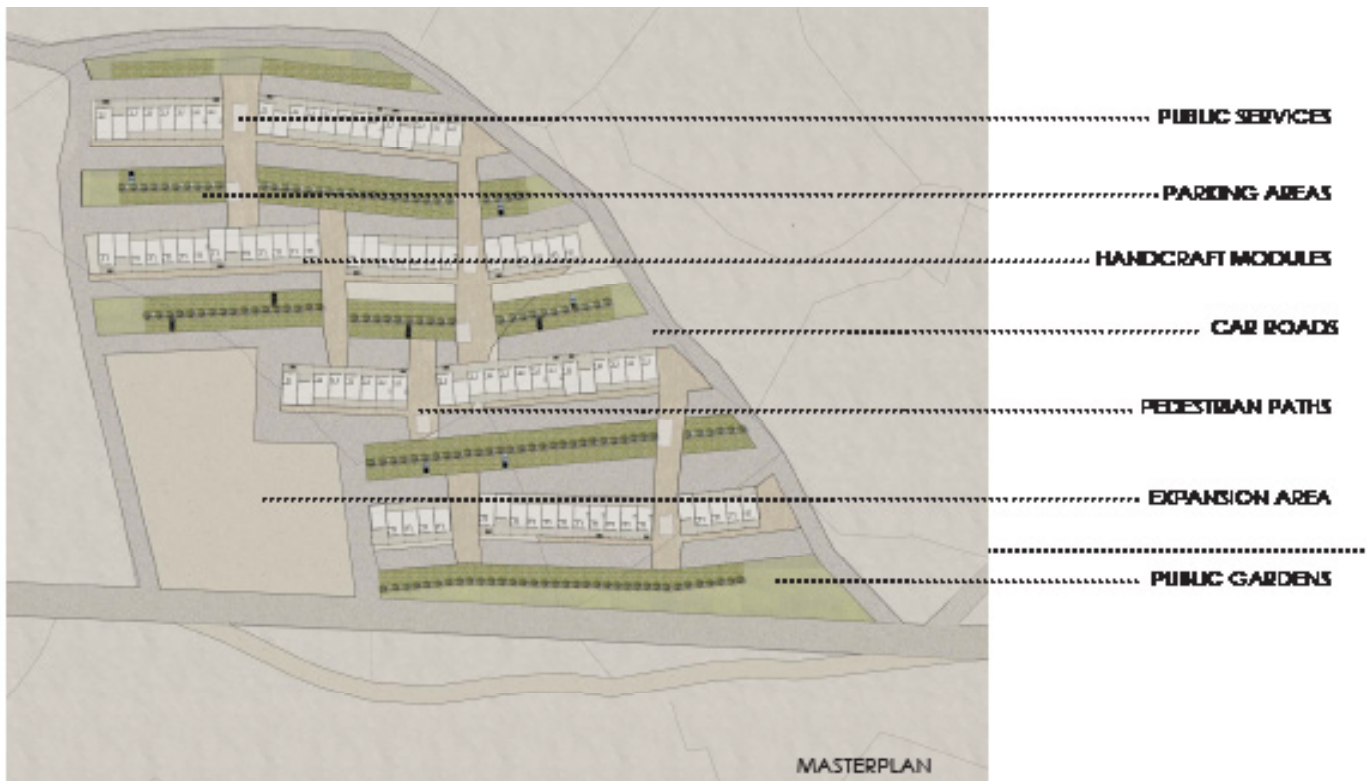

PRIMARY SCHOOL NEW CLASSES AND PLAYGROUND



DKAIKA, AREA C, WEST BANK



2013



PROMOTER: VENTO DI TERRA NGO

DONOR: UNDP (UNITED NATIONS DEVELOPMENT PROGRAMME) - CRDP PROGRAMME



EDUCATION



30.000 €



RECYCLED OF EXISTING MATERIALS, RIVER REEDS



REALIZED



The project has involved the rehabilitation of one of the school's classroom that has been made accessible from the outside through the creation of a movable wall. By exploiting the natural ventilation, it was possible to improve the thermal comfort inside the classroom. The construction of a system of shields in river reeds has helped to avoid the overheating of the walls. The project also includes a large playground, partially underground in order to create seating areas.

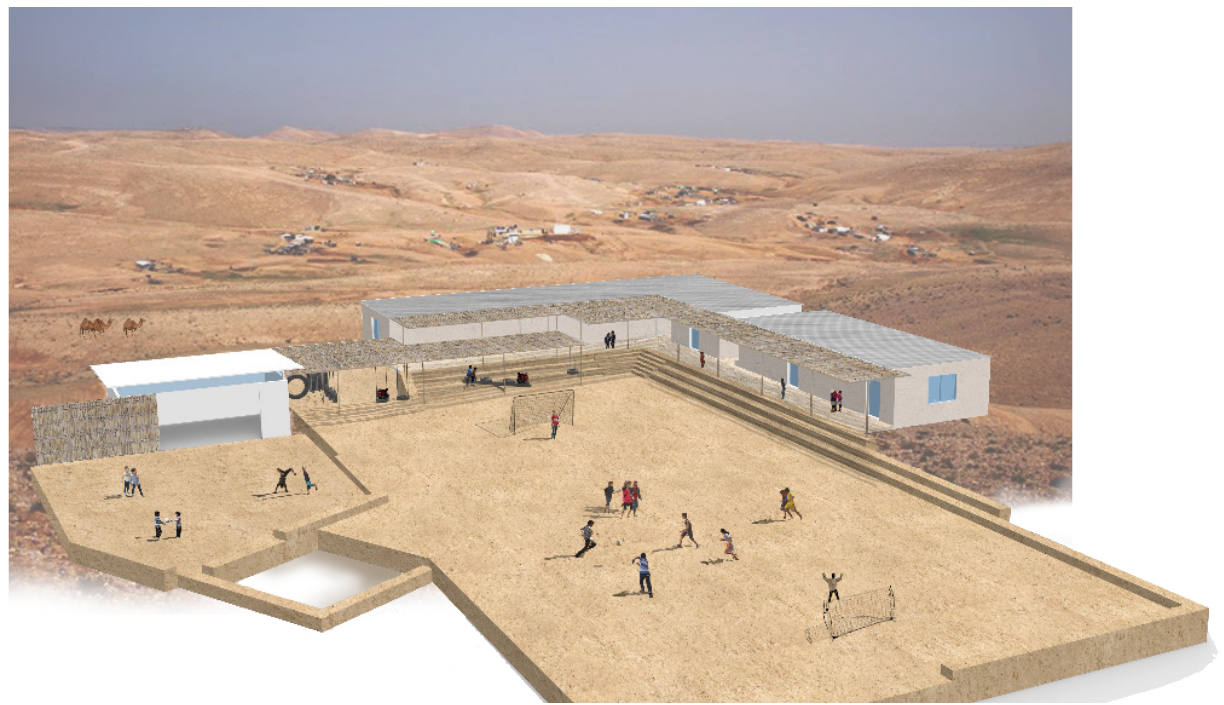

RE-MOVABLE CLINIC



AREA C, WEST BANK



2013



PROMOTER: VENTO DI TERRA NGO

DONORS: UNDP (UNITED NATIONS DEVELOPMENT PROGRAM), ITALIAN MINISTRY OF FOREIGN AFFAIRS – ITALIAN COOPERATION, BELGIAN DEVELOPMENT COOPERATION



HEALTH



30.000 €

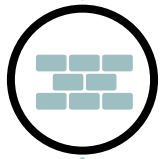

PREFABRICATED - 3 HOURS ASSEMBLY



REALIZED



The RE-MOVABLE CLINIC is the prototype of a movable system that will provide basic healthcare to people living in Area C of the West Bank. The objective is to create a space for medical activities that can fit the Israeli-imposed restrictions in Area C. The clinic can be easily transported by a normal van and can be assembled on site in less than 3 hours by unskilled people. The clinic is easily built and doesn't need high-tech solutions. All the materials and technical details have been conceived on low-tech principles, a decision derived from the necessity of constructing the whole unit locally, with materials, skills, and technologies available on the Occupied Palestinian Territories.

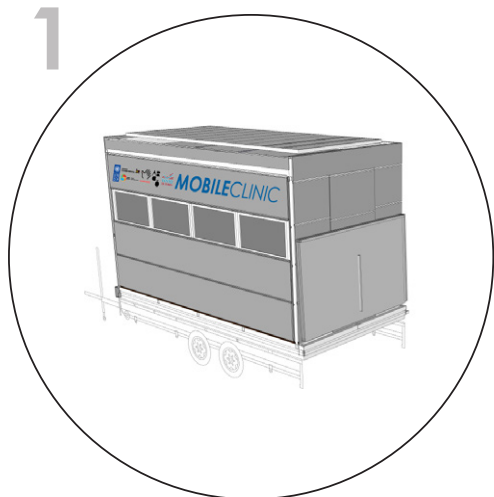
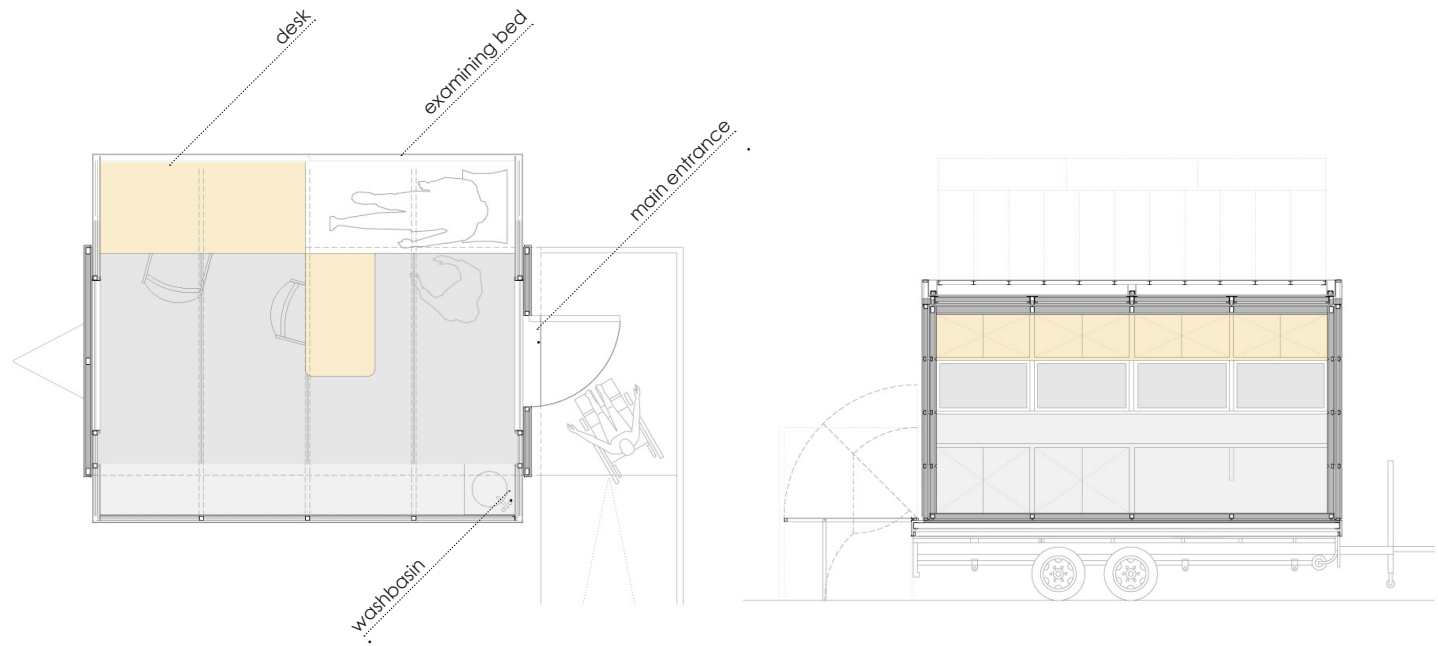

VOLUME DURING TRANSPORTATION

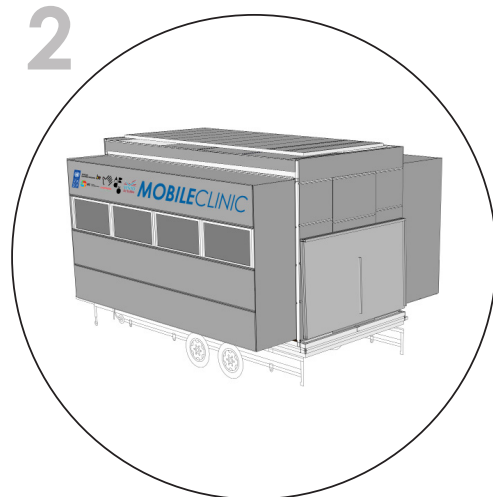

VOLUMES TRANSLATION
Horizontal direction

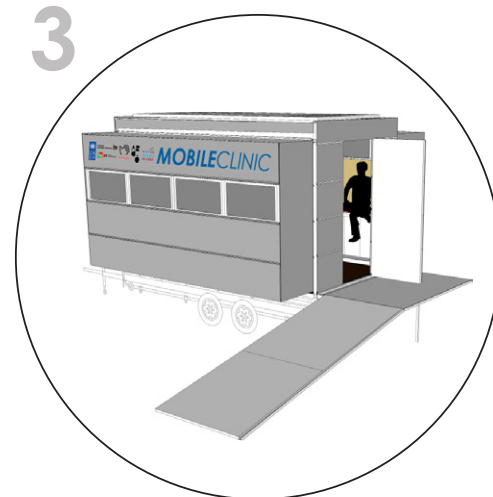

FOLDING RAMP

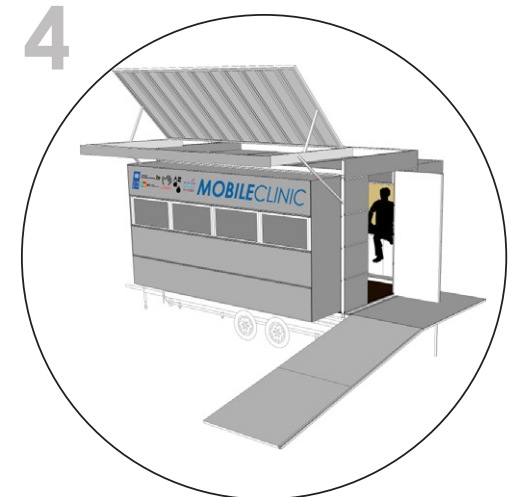

COVERING ELEMENTS
Photovoltaic cells

PRIMARY SCHOOL NEW CLASSES AND PLAYGROUND



ABU HINDI BEDOUIN CAMP, WEST BANK



2013



PROMOTER: VENTO DI TERRA NGO, JERUSALEM BEDOUIN
COOPERATIVE COMMITTEE



EDUCATION



57.000 €

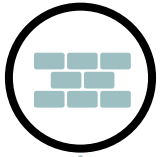

PISE' AND BAMBOO PANELS



REALIZED



This is a rehabilitation project for three buildings and the playground of the Abu Hindi's school. The main elements added to the buildings are simply a Pisé wall, constructed inside the existing metal sheet, and a bamboo layer outside, so to create a ventilated camera that protects from overheating. The space between the buildings was calibrated in order to reduce to the minimum the amount of dust and sand swiping the playground. The materials used for this spaces were rammed earth, mud bricks and dry stone. The existing difference in ground levels became an occasion to create game facilities for the children.

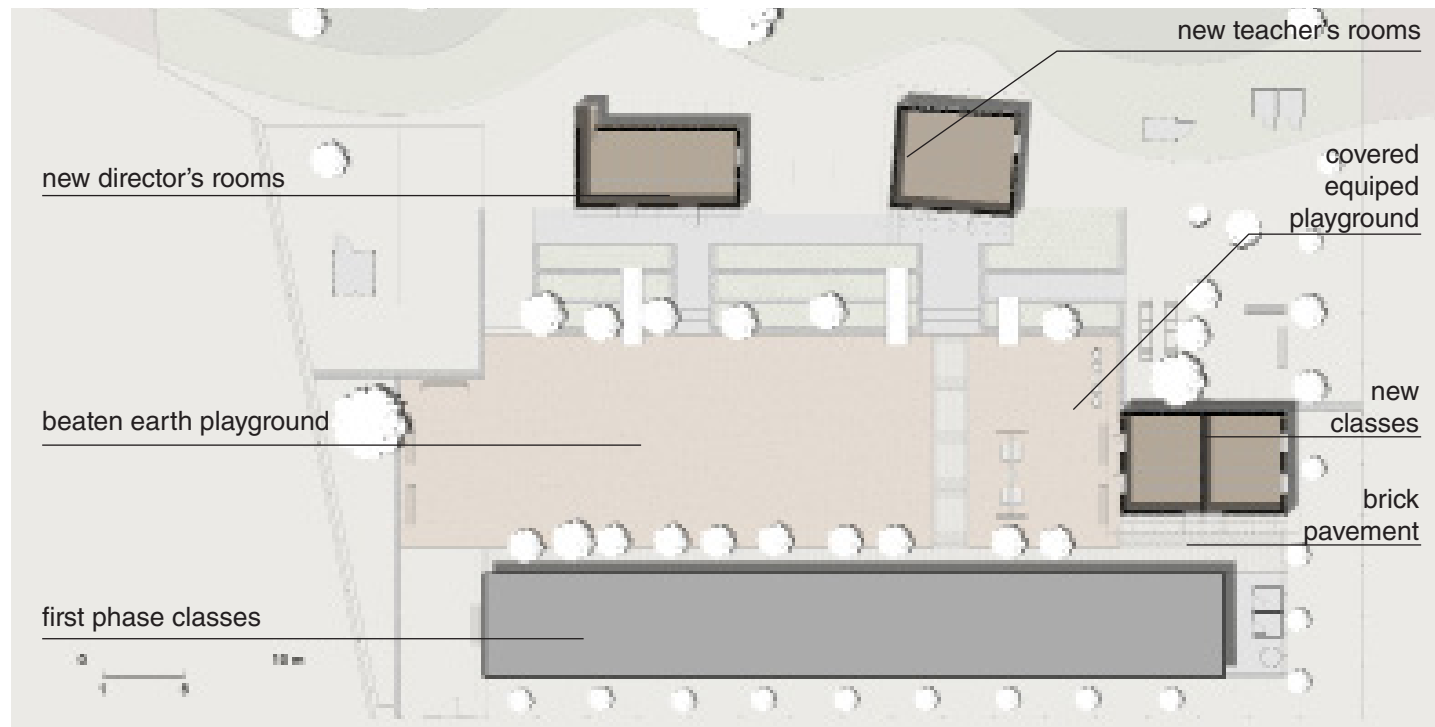

PRIMARY SCHOOL NEW CLASSES



AL KHAN AL AHMAR BEDOUIN CAMP, WEST BANK



2012



PROMOTER: VENTO DI TERRA NGO, JERUSALEM BEDOUIN CO-OPERATIVE COMMITTEE



EDUCATION



35.000 €



STRAW-BALE WALLS



REALIZED



The needs of the community were to add two classes to the existing school of Al Kahn Al Ahmar, that had already a demolition order issued by the Israeli army authorities. The chosen technique was the straw-bale wall, put on the existing concrete base. These thick and heavy structure lays on a sandbags base as protection from humidity and is contained into a wooden structure. A double ventilated roof controls the overheating, creates an outside open space and hides the building from the street.

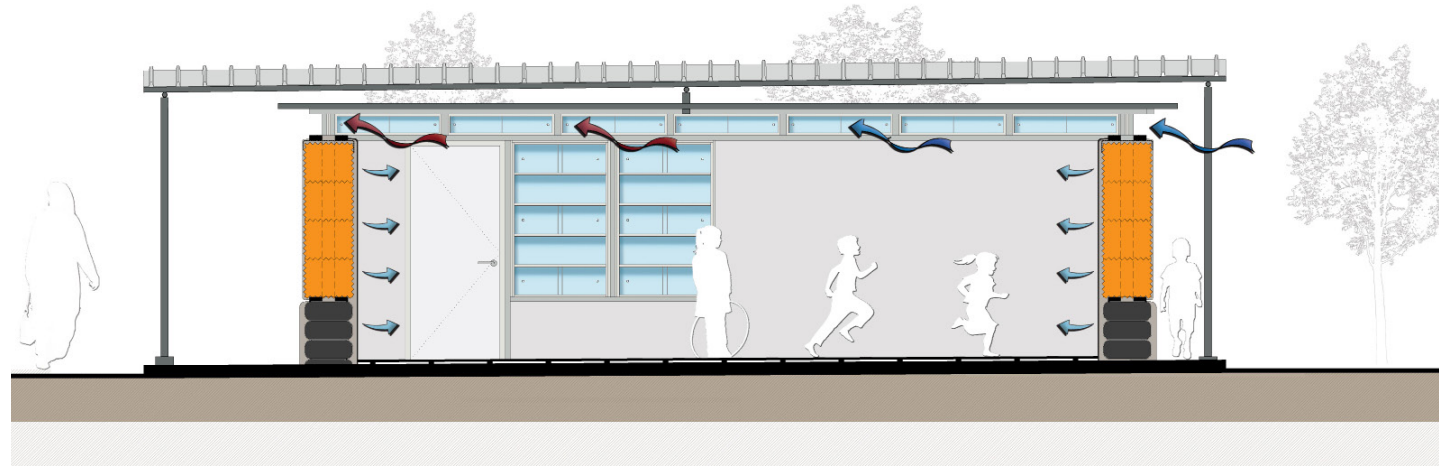
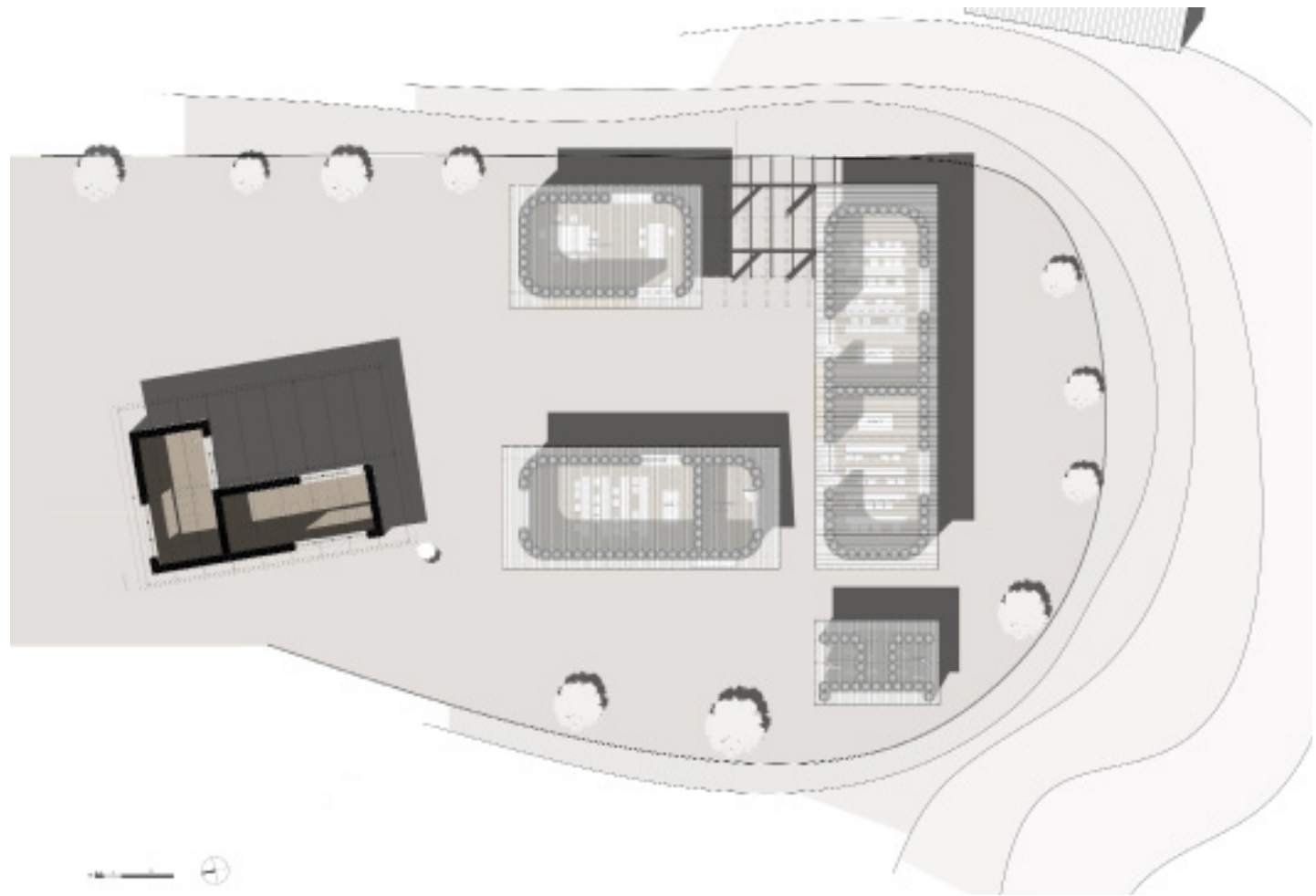

CARTONI IN MOSTRA



LODI



2012



CLIENT: GE.CO. GENITORI CONSAPEVOLI



SET-UP



150 €



CARDBOARD RECYCLED PIPES



REALIZED



The project involves the installation of a photo exhibition divided into three types of images which correspond to three types of display. The main pictures are held on a system of recycled cardboard tubes, placed on the floor and wedged in the existing structure. The tubes are partially joined together with screws and bolts, but thanks to their weight they constitute a stable and resistant object.



KINDERGARTEN



UM AL NASSER VILLAGE, GAZA STRIP



2011 - DEMOLISHED DURING THE WAR OF 2014



PROMOTER: VENTO DI TERRA NGO



EDUCATION



180.000 €

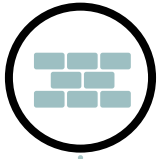

EARTHBAGS



REALIZED



For this project, the children's center "Terra dei Bambini" teamed up with MCA Mario Cucinella Architects. Here a combination of three construction techniques has been used. First, earth bags, made with the involvement of the local community; then, a ventilated metallic covering system, sloped to ensure the recovery of rain water and the integration of solar panels. Finally, a system of wooden sun-shading brise soleil that allows to maintain the façade on the inner courtyard completely open and the external one totally closed with an earthen wall.

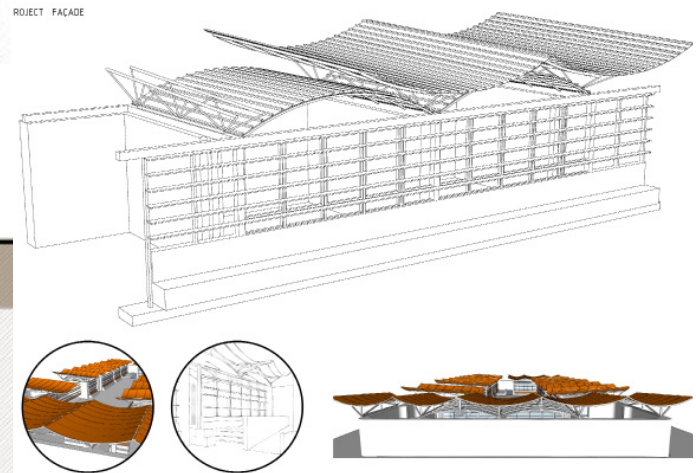
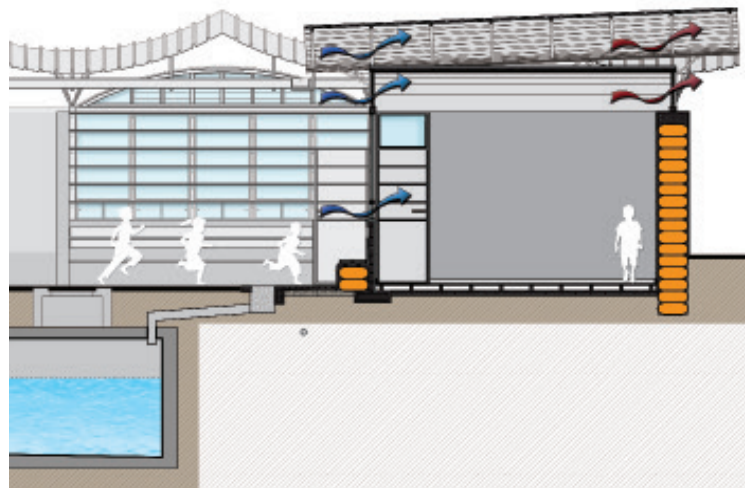
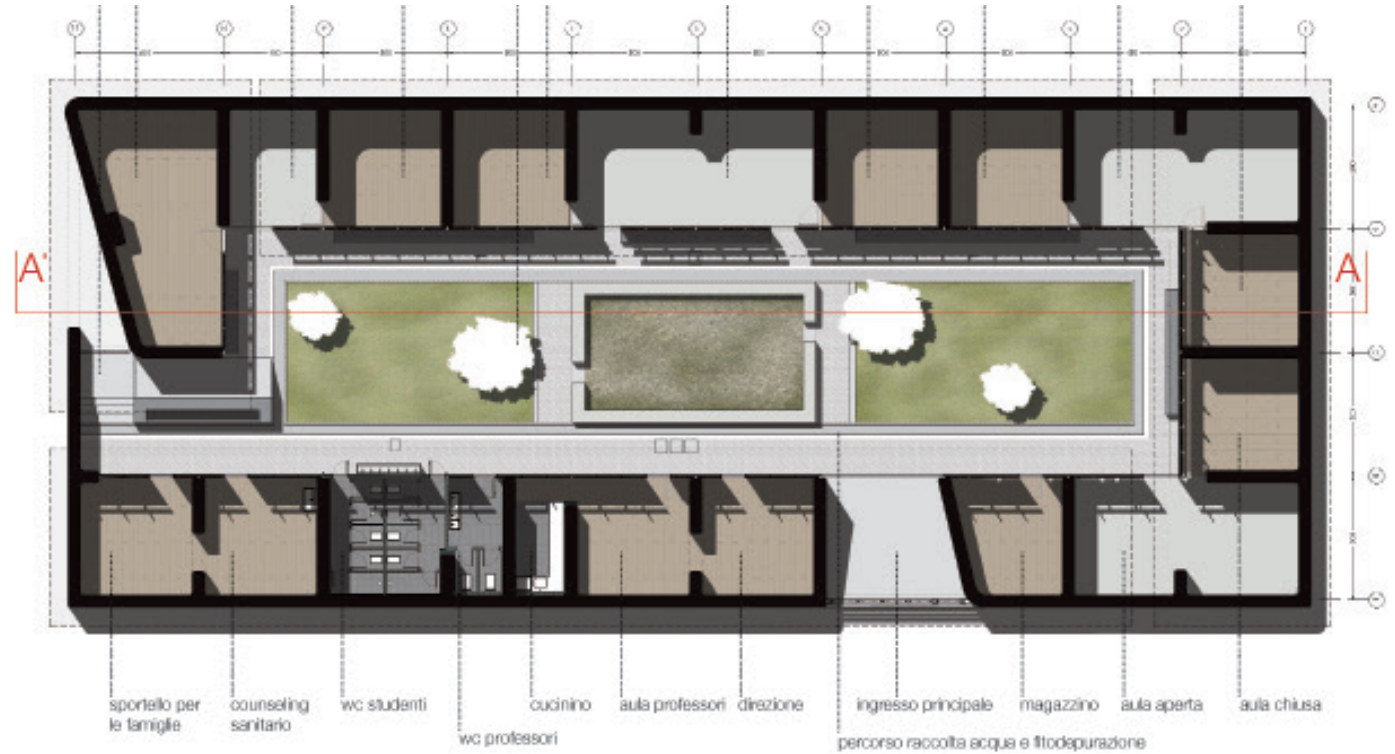
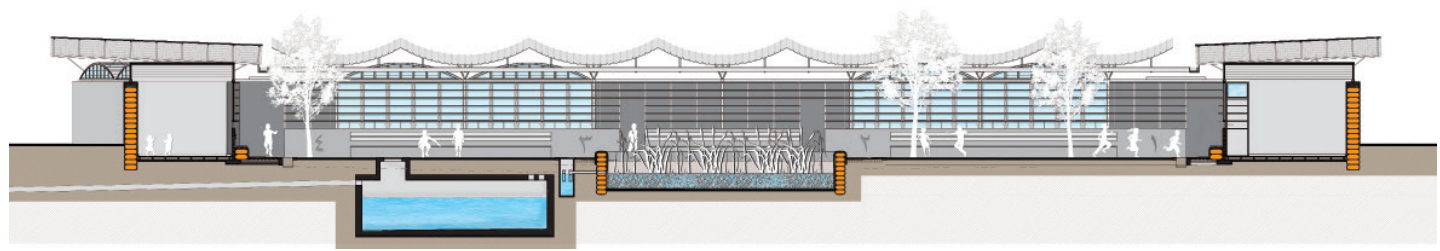

LIBRARY



AL AZARJE, WADI ABU HINDI BEDOUIN CAMP,
WEST BANK.



2011



PROMOTER: VENTO DI TERRA NGO, JERUSALEM BEDOUIN
COOPERATIVE COMMITTEE



EDUCATION



-



PISE' AND BAMBOO PANELS



DESIGN

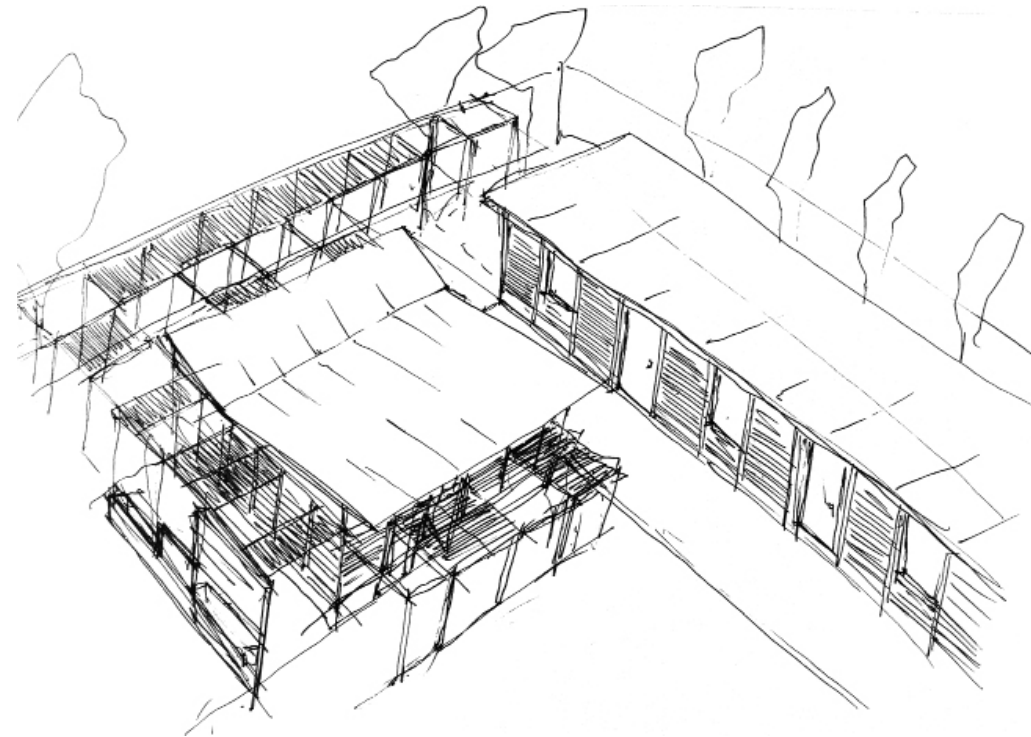

The project constitutes the second phase of the school in the desert project, from which it adopts the technical choices and constructive techniques. The new library is proposed as a new volume of squared plan articulated in two areas: from one side the main reading room, defined by library-walls and completely opened to the outdoor space so to become a place for people to gather and pass-through. From the other side, the areas for facilities, more closed and protected. This articulation is expressed as well in the roof, solved in two opposed slopes, which recreate the natural ventilation mechanism from the school in the desert. The indoor spaces of the library are linked to the outdoor ones by the modular pergola made of bamboo panels.

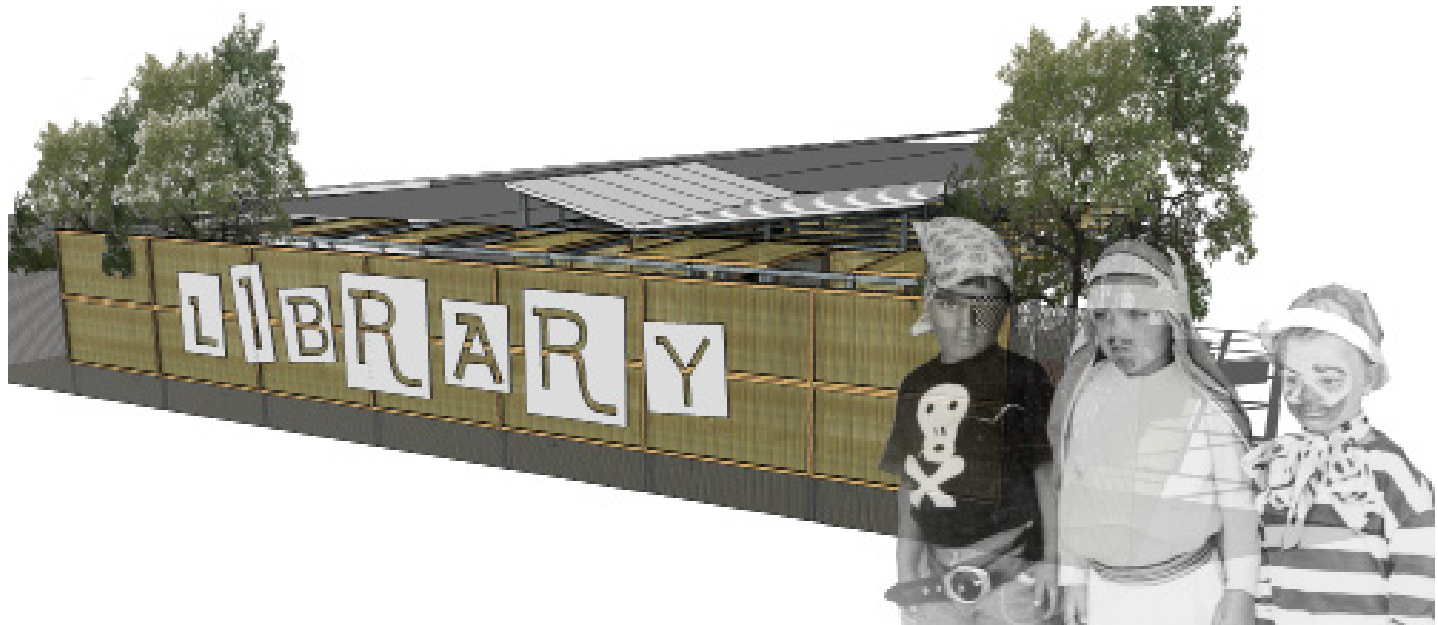
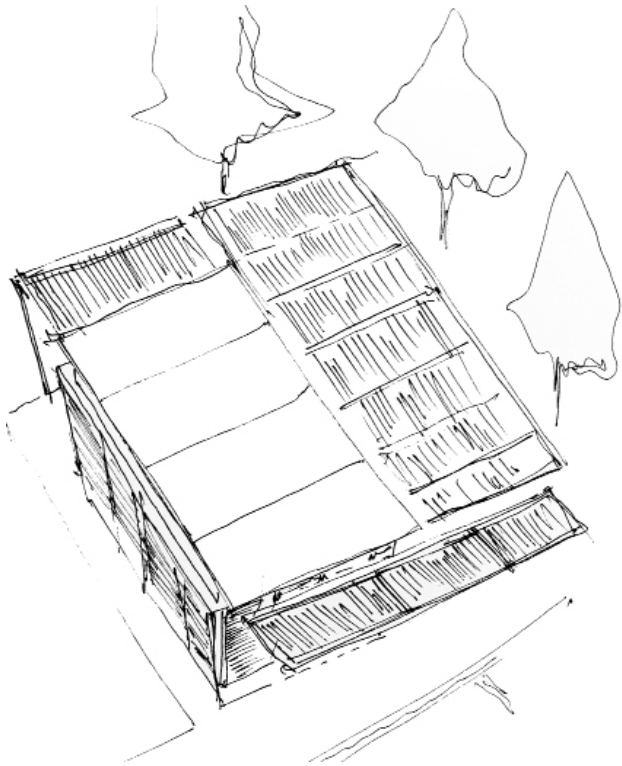
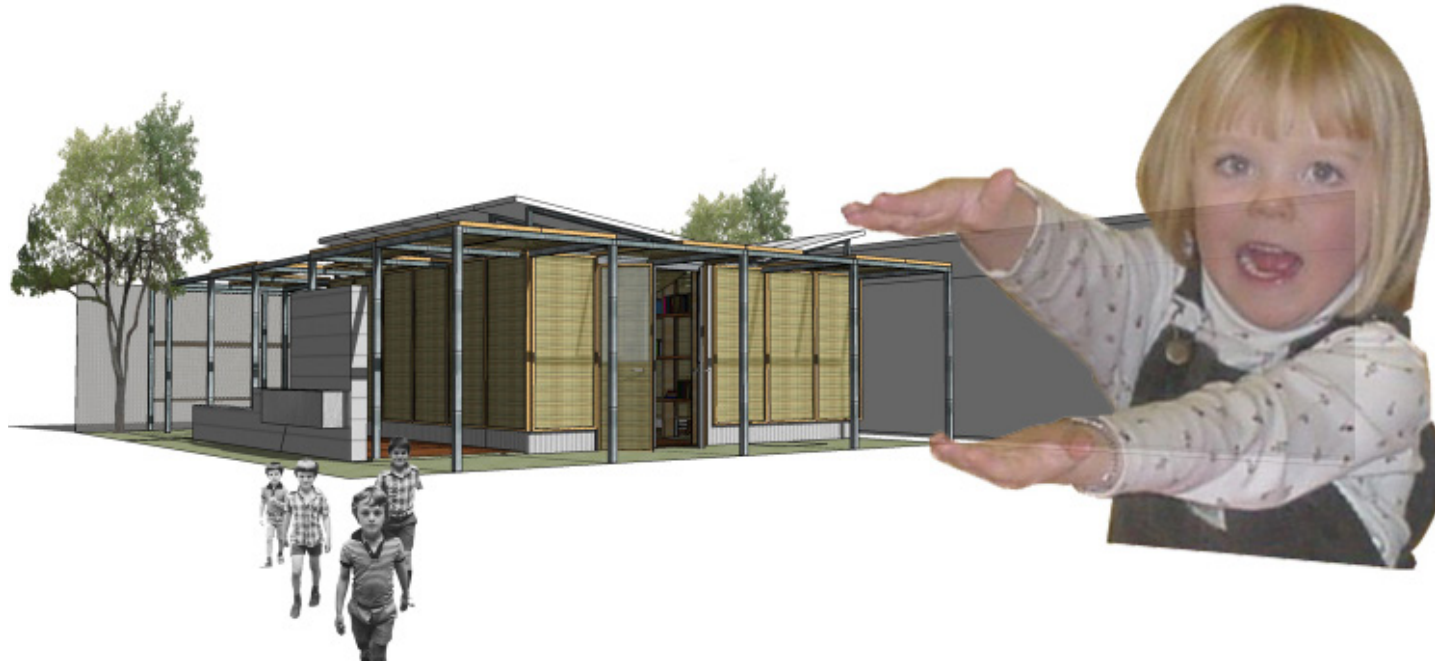

PRIMARY SCHOOL



ABU HINDI BEDOUIN CAMP, WEST BANK.



2010



PROMOTER: VENTO DI TERRA NGO, JERUSALEM BEDOUIN COOPERATIVE COMMITTEE

DONOR: MCA MARIO CUCINELLA ARCHITECTS, CEI (CONFERENZA EPISCOPALE ITALIANA), UNICEF, UN OCHA (UNITED NATIONS OFFICE FOR THE COORDINATION OF HUMANITARIAN AFFAIRS)-ERF PROGRAMME



EDUCATION



45.000 €

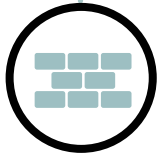

PISE' AND BAMBOO PANELS



REALIZED



The project faces particular restrictions imposed by the Israeli military authority, which state the maintenance of the existing situation and the impossibility of volumetric reshaping for the existing school building. The project focuses on two main themes, which are natural ventilation and thermal insulation. Natural ventilation was created by raising and tilting the roof, thus realizing an efficient air circulation system. The existing metal sheet roof was substituted with sandwich panels, to improve the whole building thermal insulation. The thermal insulation of the external walls was realized by adapting the pisé technique to local needs. The final result in the school is a wall 34 cm thick, including lime plastering, bamboo panels as quarterdecks, soil and straw layer, existing external metal sheet, air cavity and a final external shading bamboo panel.

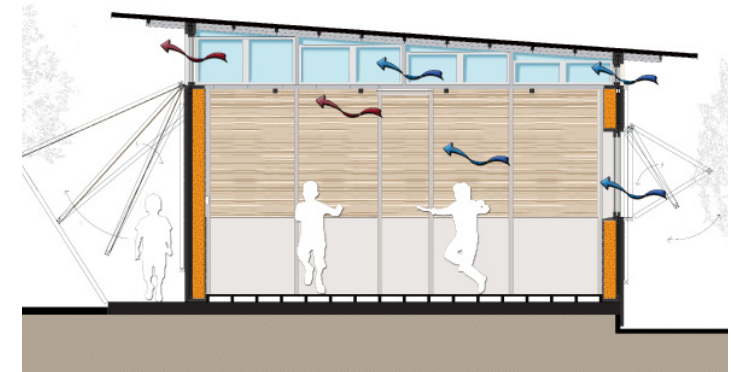
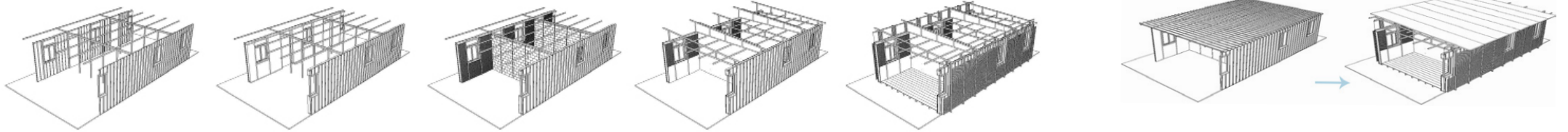
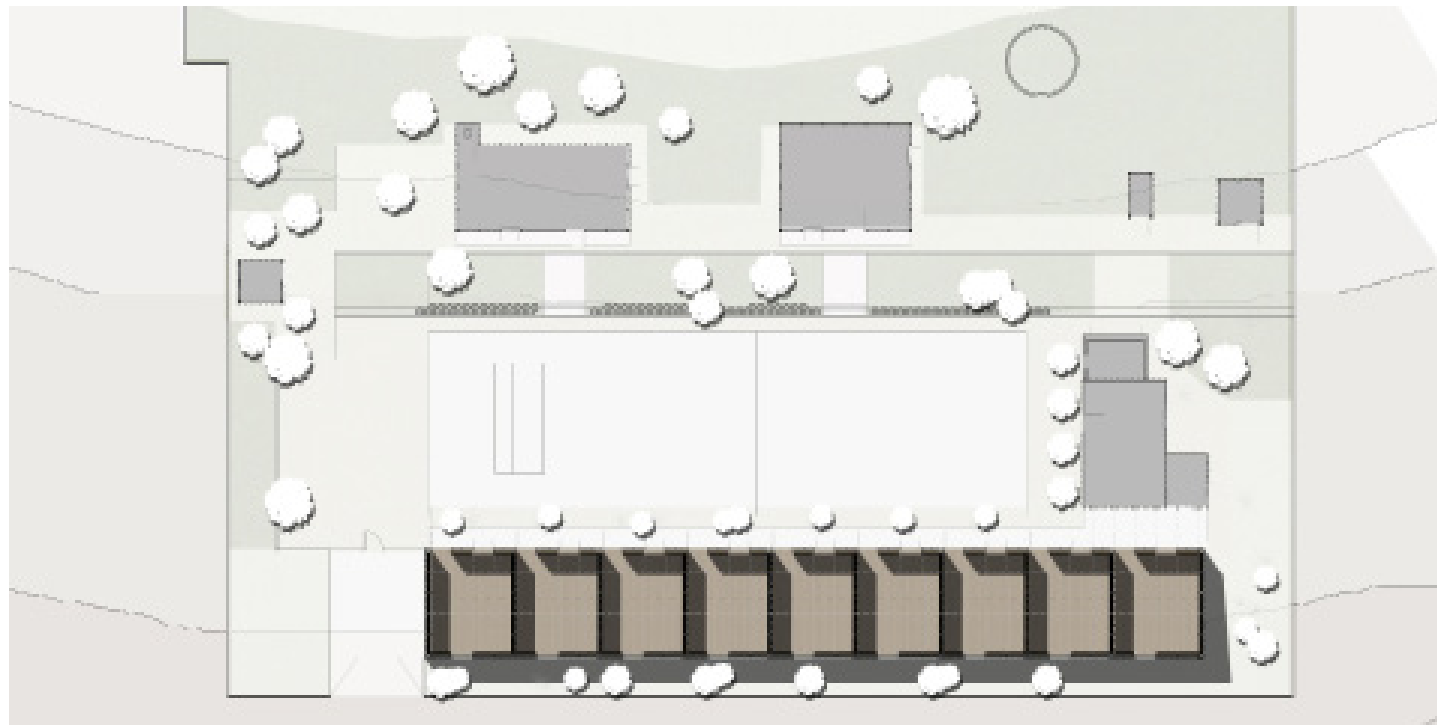

PRIMARY SCHOOL



AL KHAN AL AHMAR BEDOUIN CAMP, WEST BANK.



2009



PROMOTER: VENTO DI TERRA NGO +
JERUSALEM BEDOUIN COOPERATIVE COMMITTEE



EDUCATION



80.000 €



EARTHSHIP



REALIZED



The starting constraints for this project were quite complex: absolute prohibition of using cement and foundations, due to the prohibition for the Palestinians of non-temporary artefacts in the area C of the West Bank; velocity and simplicity in the construction; minimum costs and local non-skilled manpower. From these constraints came up a project that brings together the rapid and simple construction with a high-level of comfort conditions. The walls made of tires filled with earth and the roof made with sandwich panels supported by wooden beams, were built in just two weeks. All the works have been carried out by manpower from the local community, under the technical direction of ARCò.

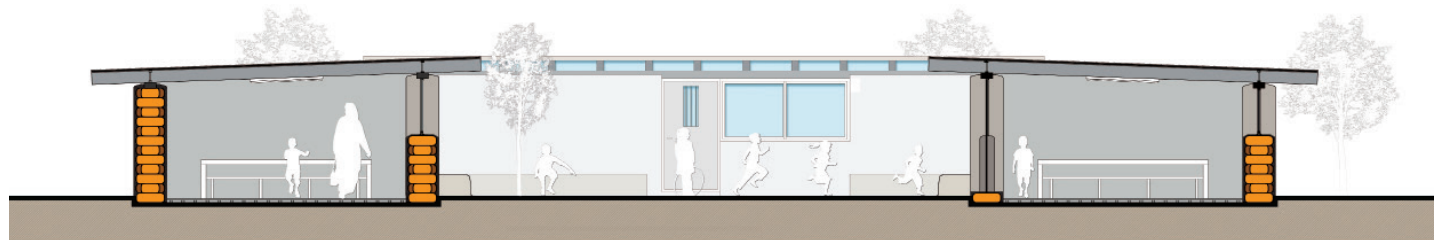
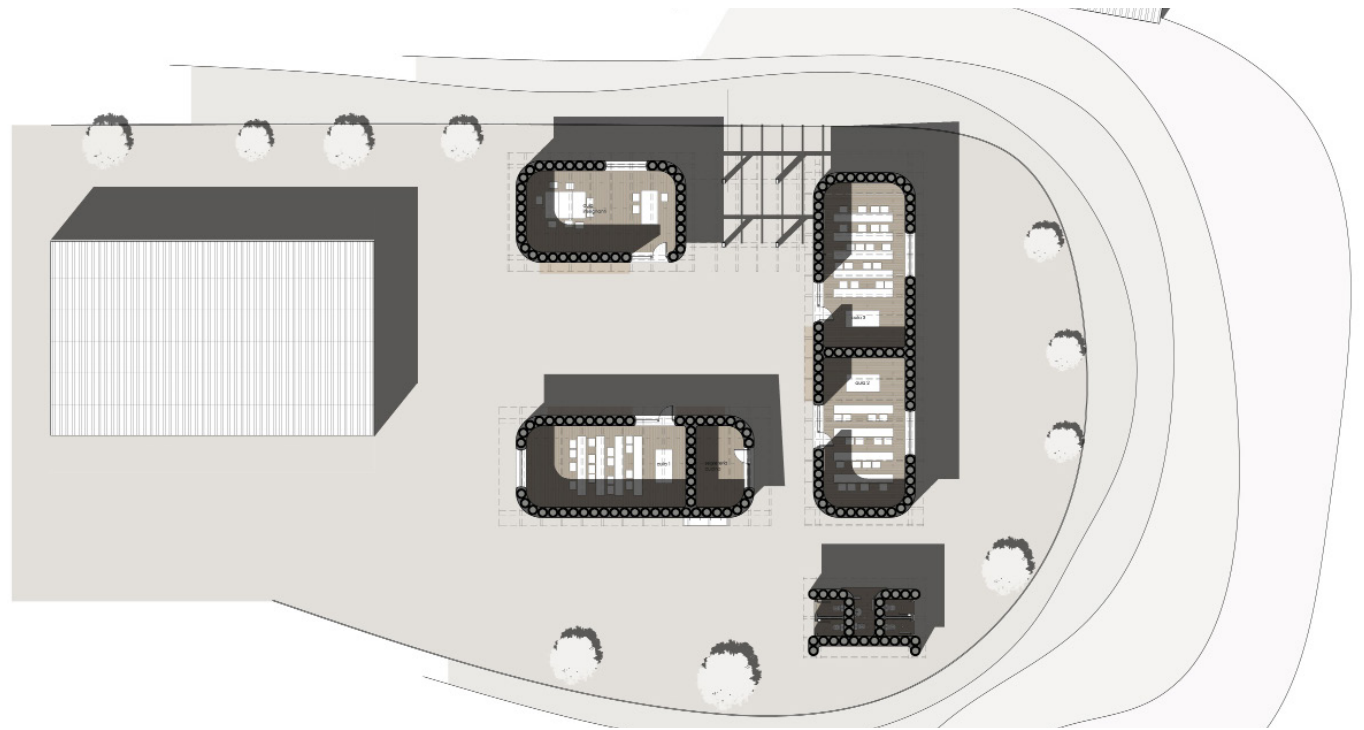

C O M P E T I T I O N S

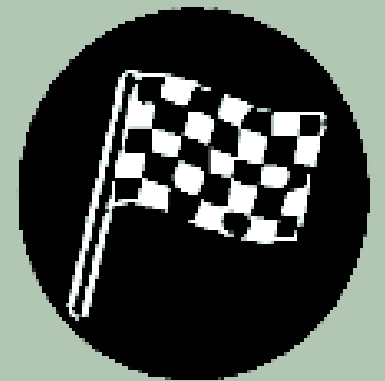

ENHANCEMENT OF THE BOURBON TANK IN THE CITY OF FORMIA



FORMIA (LT)



2014



CLIENT: MUNICIPALITY OF FORMIA



PUBLIC EQUIPMENT



-



MIXED



COMPETITION

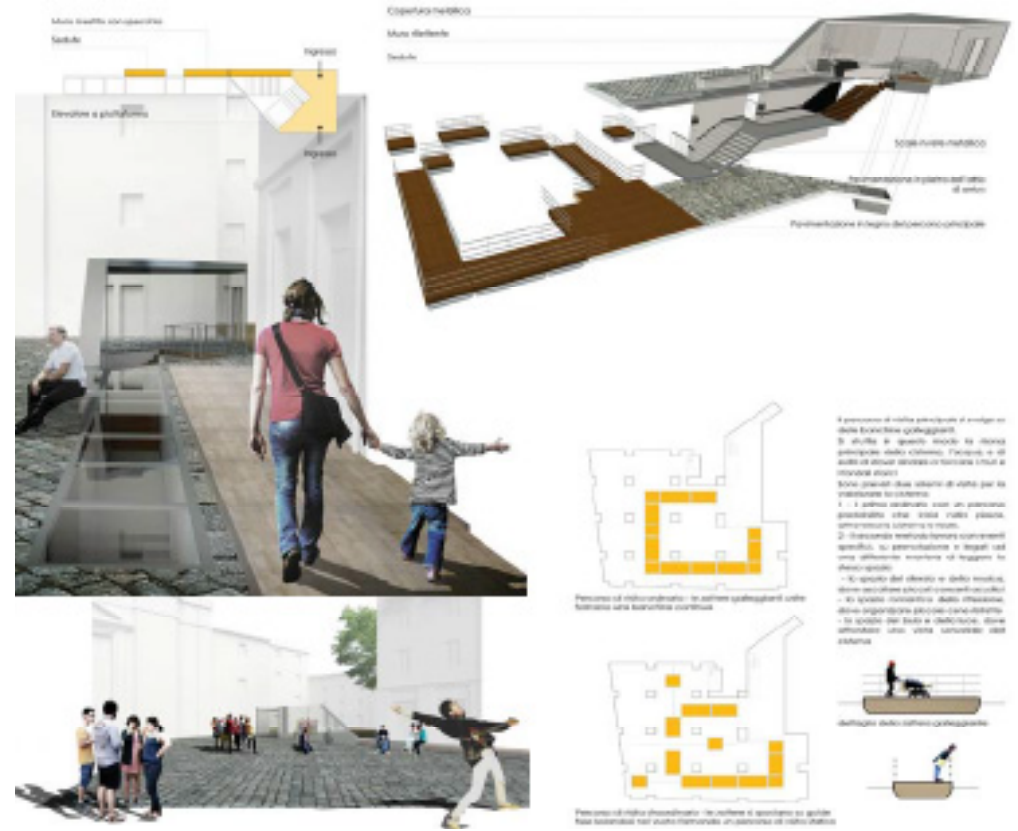

The project intended to realize a complexity of actions with the simple, familiar gesture of building a wall. This plays as a cut in the horizontal space of the square, and in the vertical space of the perceived public void. The goal was to design a high standard architectural artefact that could contribute to the environmental quality of the public space by working on different levels and at the same time as a virtual connection. In order to do so, two parallel lines of thought were developed: one lying on the surface and dealing with the relation between the public space and the built environment, and the other one working underneath, in the underground space of the void cistern

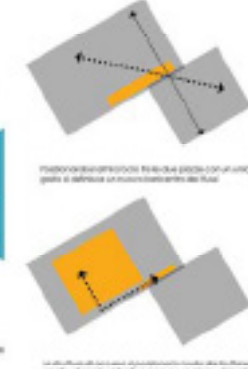
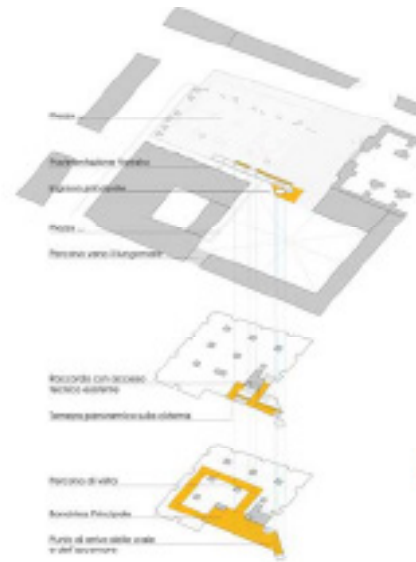
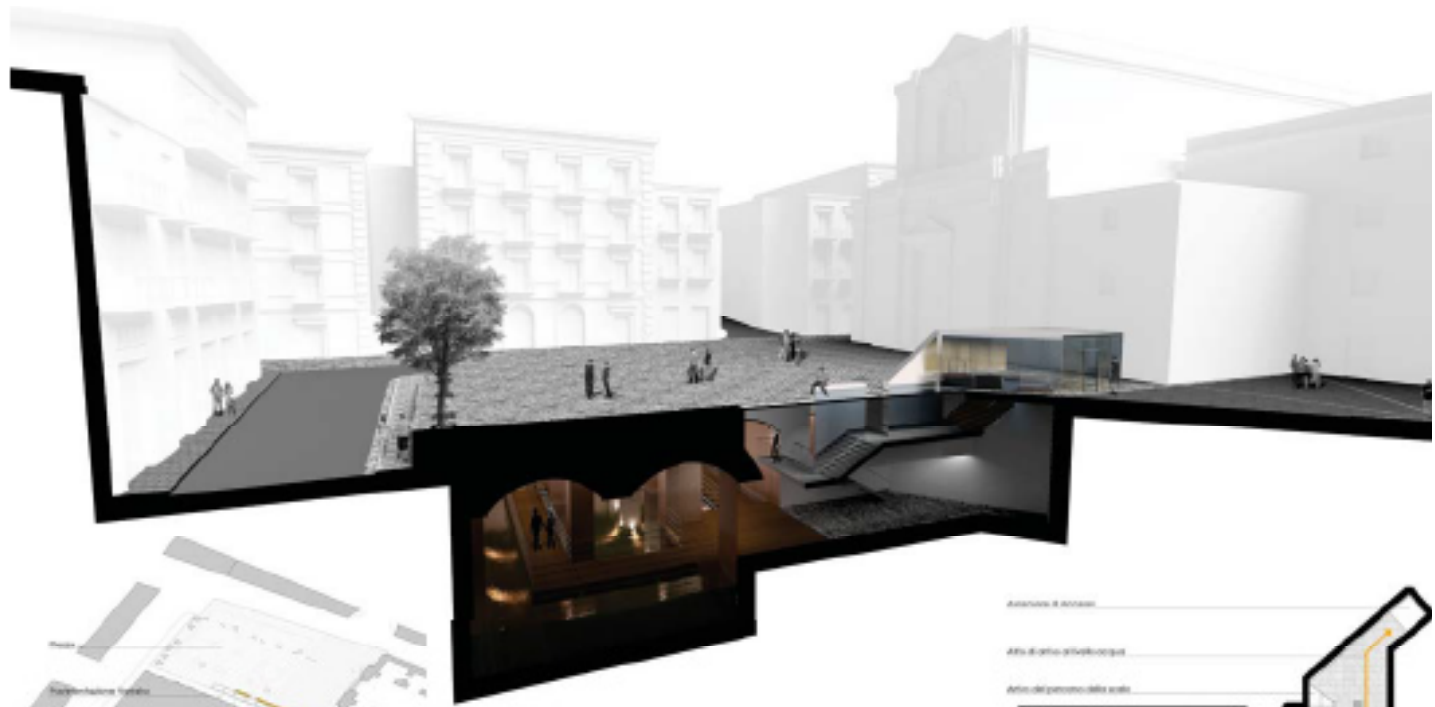

RECOVERY OF THE SPACE OF BUSSA OVERBRIDGE



MILAN



2014



CLIENT: MUNICIPALITY OF MILAN



PUBLIC EQUIPMENT



-



MIXED

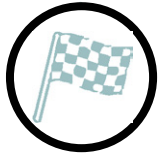

COMPETITION



SCHEMI DI FUNZIONAMENTO DEI NERI/INFRANTI/STETTUSA

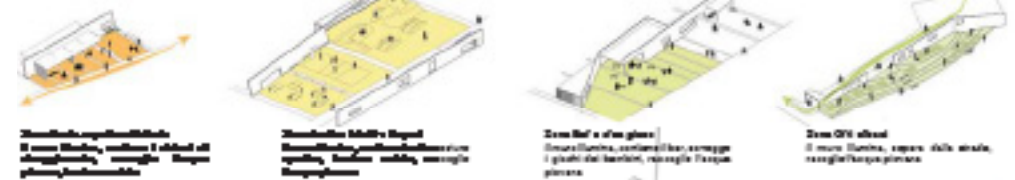

Nuovo piazzale di ingresso alla scuola



Area di sosta con alcuni di funzionamento



The design of the rehabilitation of the spaces of Bussa overpass stems from a reflection on the ways of use of the city and on the possibility of using the weak users, in this case children, as the real engine of reactivation of public space. The design followed three basic guidelines: defining some key points as the sequence of nodes, situations, centres of gravity breaking the linearity of the overpass; providing for the establishment of a macro-area, which develops in a linear completely accessible to children by defining a landscape playful throughout the intervention; reflecting on energy and economic compensation of the new spaces created.

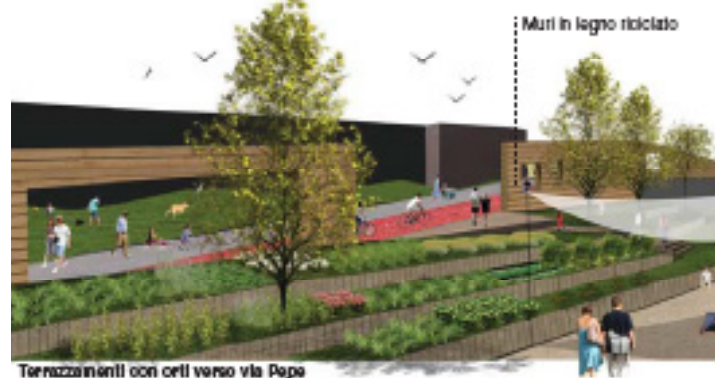
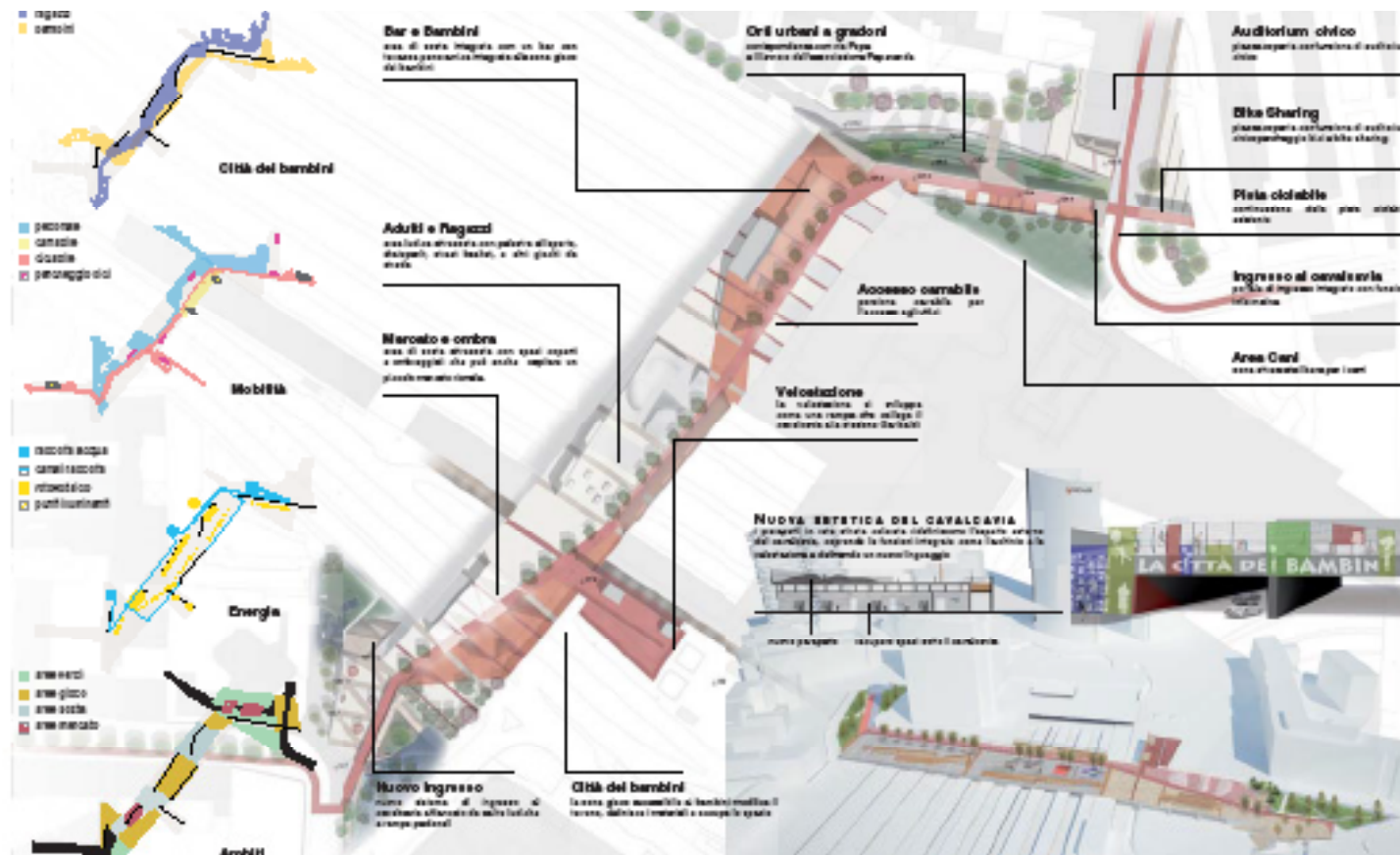

VELOSTAZIONE



La velostazione viene concepita come un edificio snello, che permette contemporaneamente il passaggio di livello del cavalcavia alla stazione Cavalcavia e lo stationamento pubblico di 600 biciclette. È realizzata con una struttura di acciaio e tamponamento con vetri colorati protetti da una griglia metallica striata e sfaccata.

Lo stesso sistema di protezione continua nel parapetto del cavalcavia dando omogeneità all'intervento.

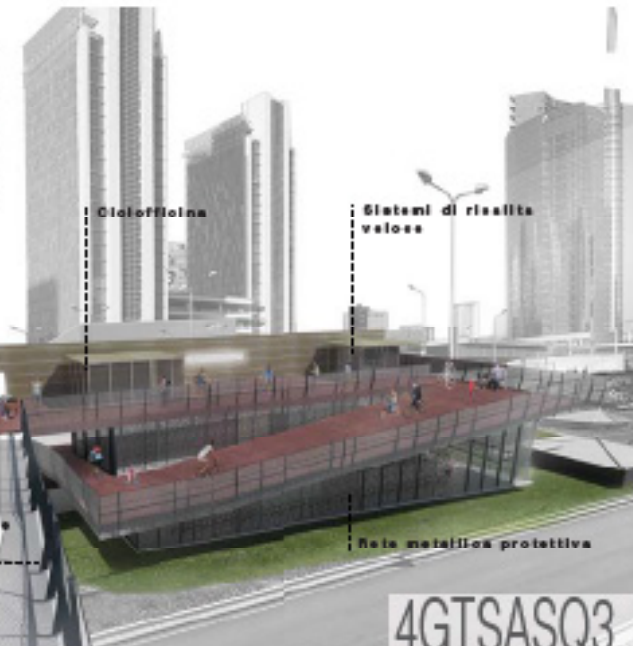
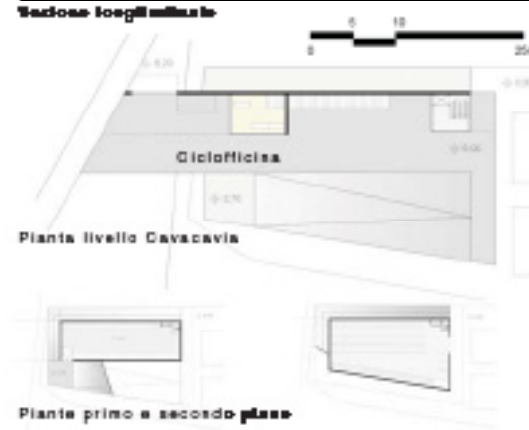

THE NEW CIVIC CENTER IN "ISOLA" DISTRICT IN MILAN



MILAN



2014



CLIENT: MUNICIPALITY OF MILAN



PUBLIC EQUIPMENT



-



WOOD AND STRAW



COMPETITION



The wall is the founding act of architecture: it defines and embraces spaces, protects and isolates them, defines the belonging of a place to a community. The project for the Civic Center in the Isola neighbourhood originates from a reflection on the value of the construction of a wall may have for the inhabitants. In line with the participatory process that has led to the definition of the functional program, this project intended to erect the building following the principles of assisted self-construction.

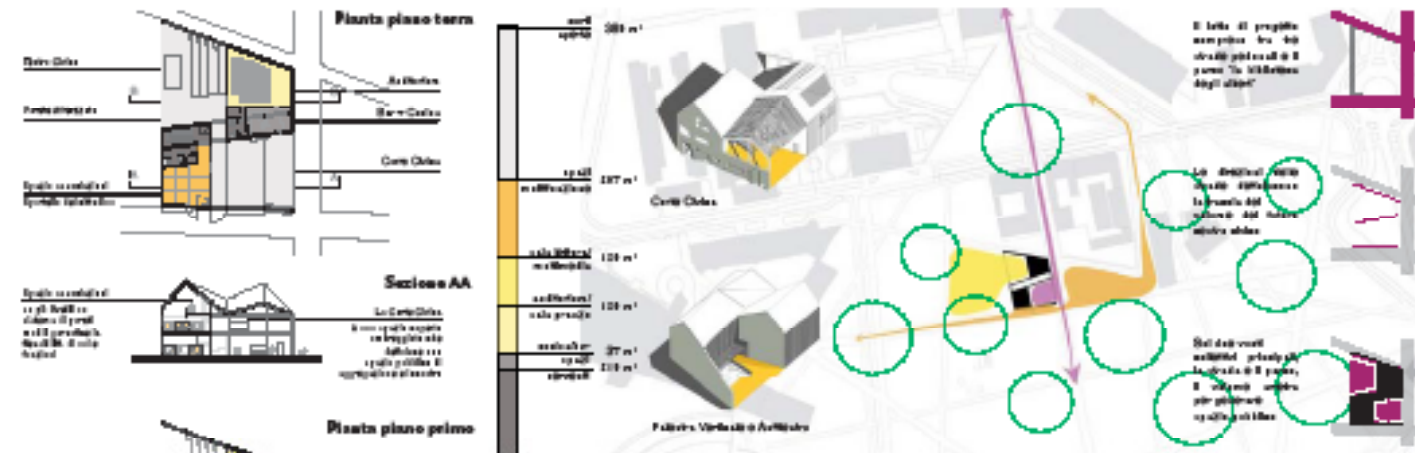
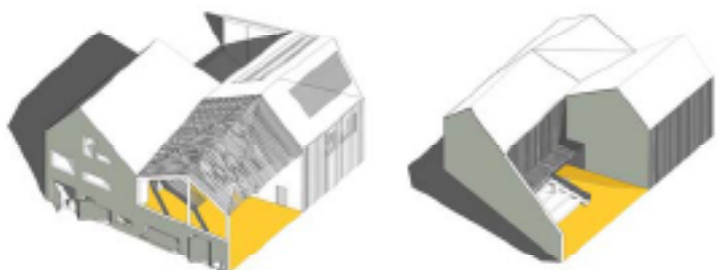
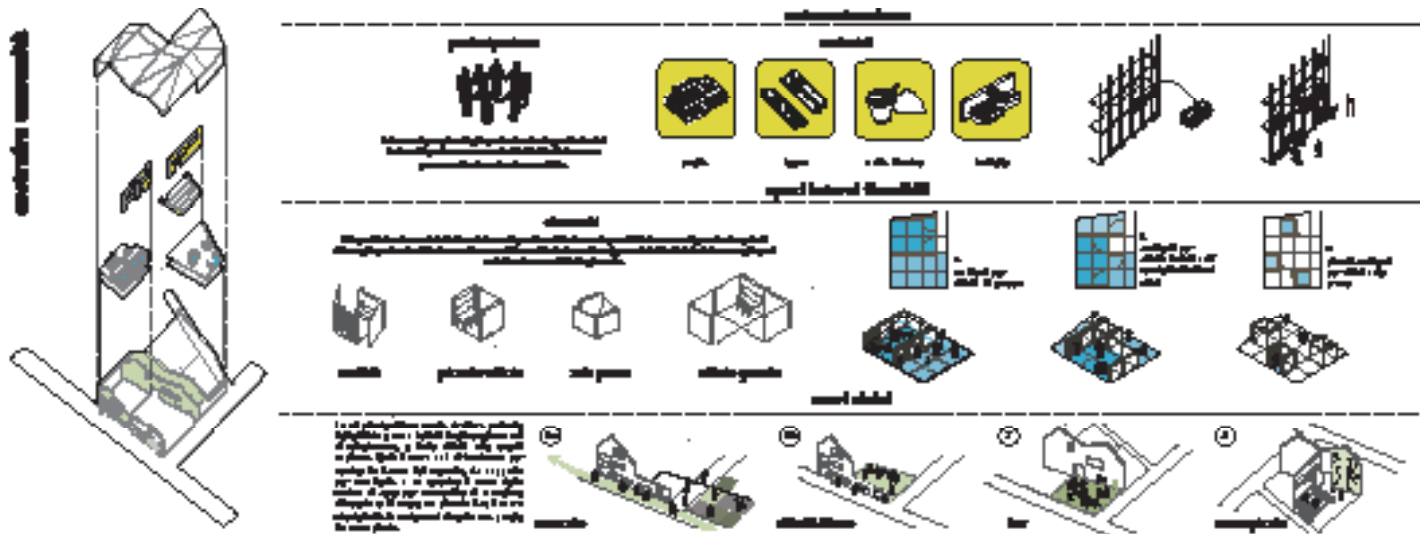

EXPO 2015

ARCHITECTONIC FACILITIES AND RELATED



MILAN



2012



CLIENT: EXPO 2015 S.P.A.



PUBLIC EQUIPEMENT



-



STRAW BALES WALLS

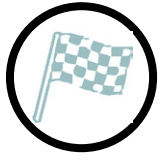

COMPETITION/PARTICIPANT



This project integrates sustainability in the whole architectural process, since the first steps of design. The use of engineering solutions is limited to the control of comfort level and the bioclimatic architecture techniques. The modular balloon-frame structure of wood and straw can be easily dismantled after the event to reuse the materials, or re-assembled in other places to host new functions.

Team: ARCò, E-plus Studio, Made associati, Metamorphosys, U-Boot.

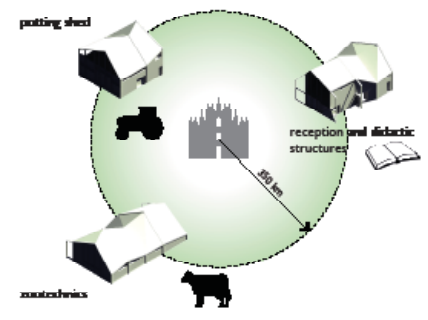
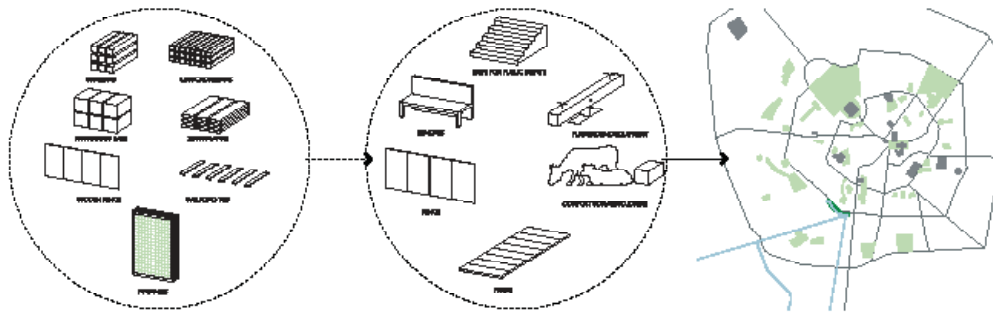

POSSIBLE REUSE

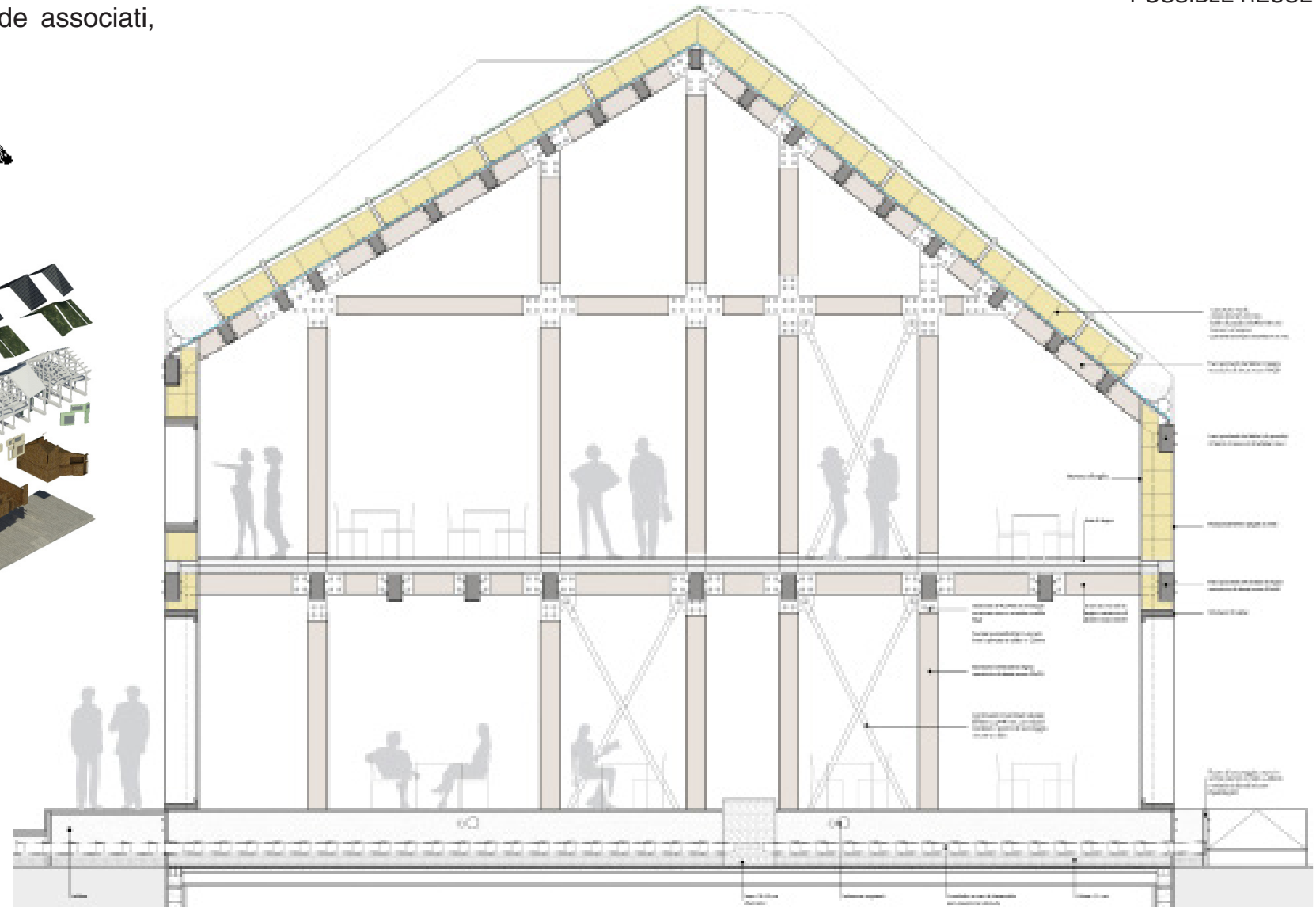
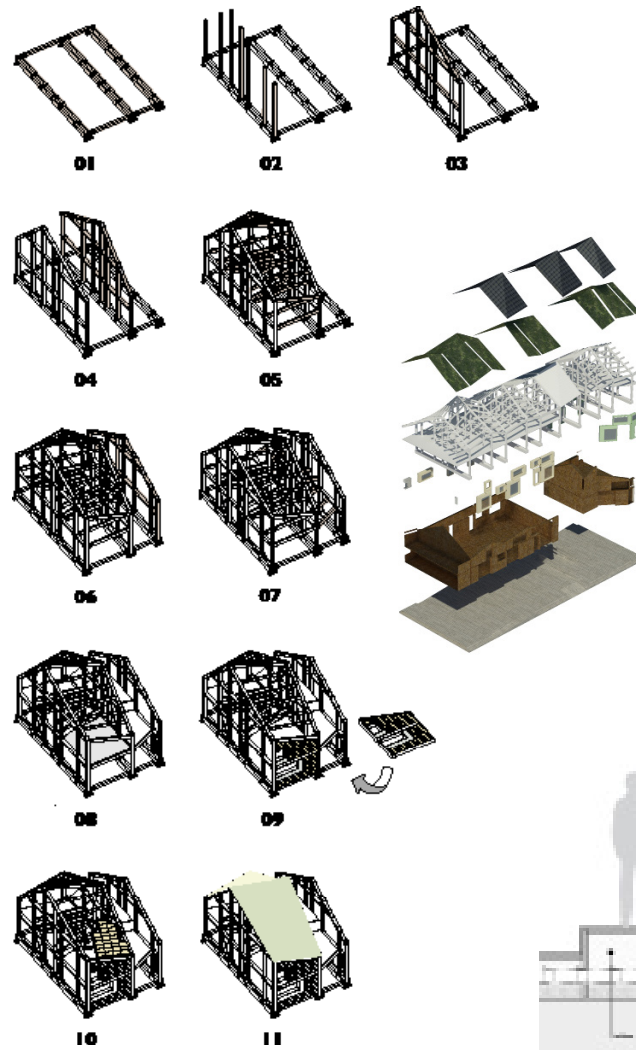

A SCHOOL FOR CAVEZZO



CAVEZZO (MO)



2012



CLIENT: FONDAZIONE RENZO PIANO



EDUCATION



-

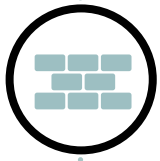

BALLOON FRAME STRAW BALES WALL

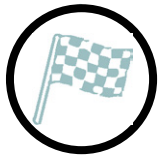

RESTRICT COMPETITION/PARTICIPANT

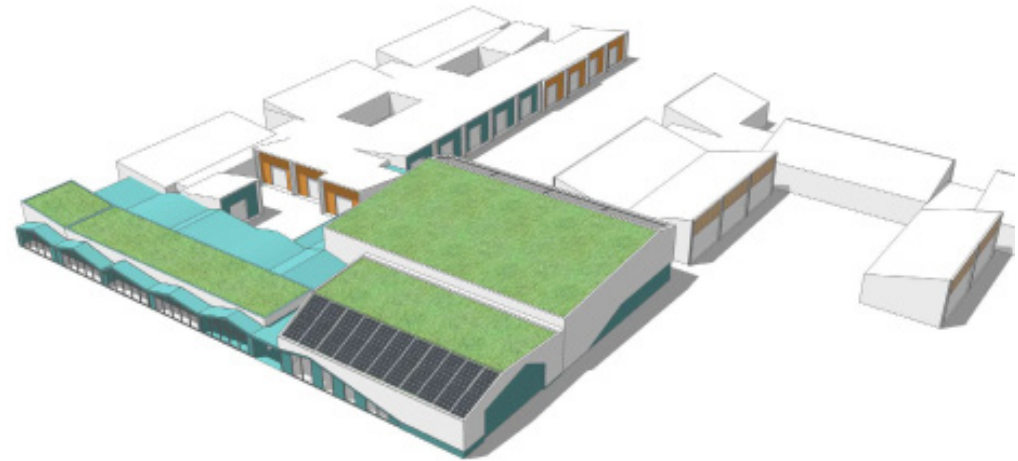

The Spring 2012 earthquake strongly signed the local community, so the project started with an investigation about citizens' perception of the place as it was. The collection of memories informed the strategy for the design of the outside spaces: a small courtyard was created between the existing and the new buildings, as core of distribution and functions. The new building was designed with a compact shape to leave space for outdoor activities. The used natural structures consisted of wooden structures and straw bale prefab walls. Environmental strategies as solar greenhouses outside the workshops were used to reduce the energy usage. The green roof, together with the straw-bales walls, strongly cuts the energy losses in wintertime, while natural ventilation refreshes the building during summertime, when PV panels harvest energy.

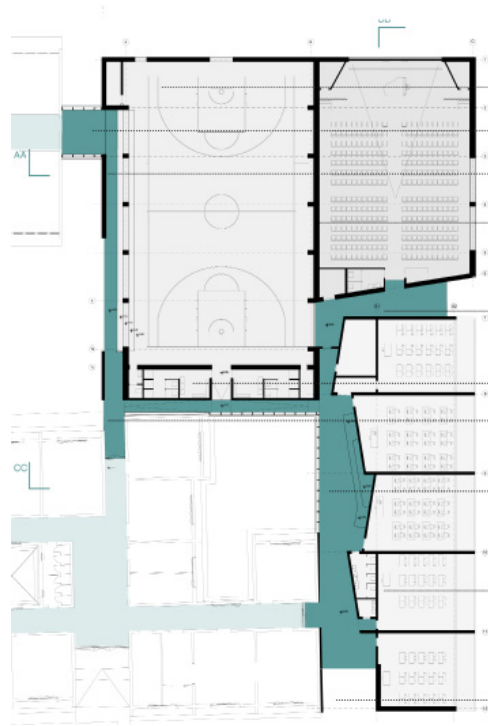

Una scuola per cavezzo

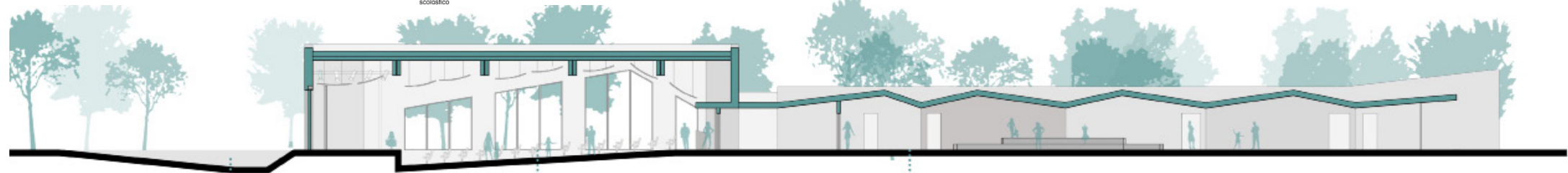
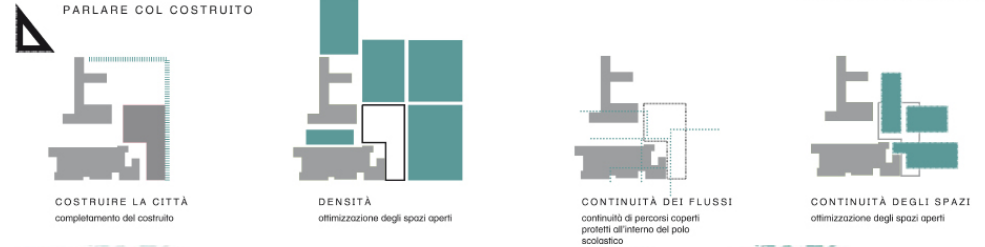
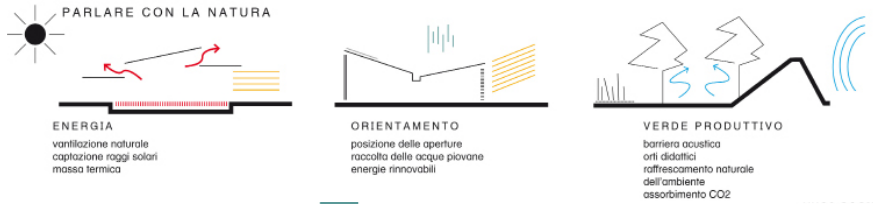
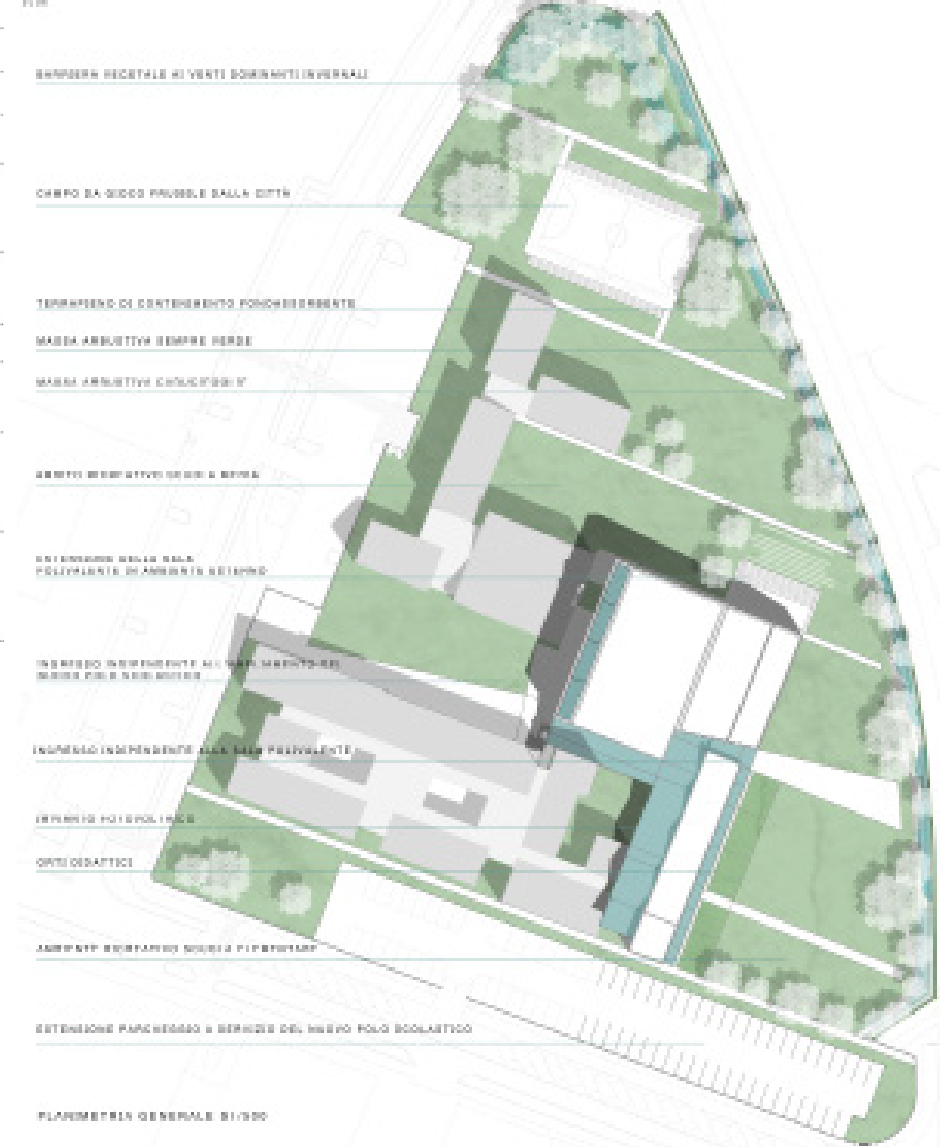

ambito esterno della

sala polivalente

spazio collettivo per intervallo

SEZIONE BB S1/200

W O R K S H O P S



GREB AND STRAW IN PALESTINE



AL KHAN AL AHMAR BEDOUIN CAMP, WEST BANK.



2015



CRDP



PRACTICAL/THEORETICAL

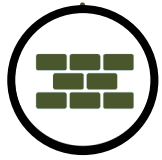

GREB



The Workshop took place in the Bedouin village of Al Khan Al Ahmar - East Jerusalem, within the program of “The Community Resilience and Development programme for Area C and East Jerusalem” funded by the Swedish, Austrian and Norwegian governments. Students from the Bedouin community participated to the lectures and then contributed to the construction of a wall made with straw using the technique of greb. This technique involves the use of panels of wood and liquid plaster mainly based on lime, in order to obtain a perfectly coplanar surface, more resistant to weathering.



THE GREB STRAW BALE BUILDING TECHNIQUE

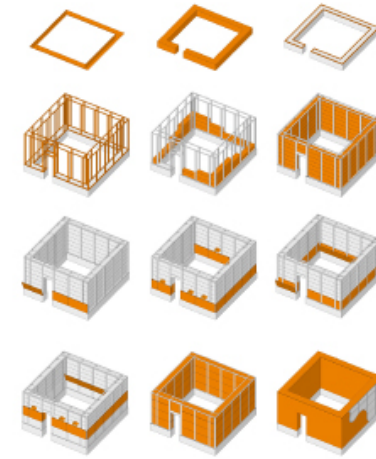

تقنية البناء باستخدام بالات القش

INSTRUCTION BOOKLE - LOW ENVIRONMENTAL - IMPACT REHABILITATION - ARCò - Società Cooperativa



PICTURES

NOTE:

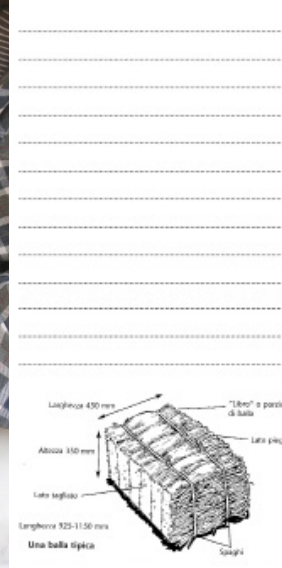

INSTRUCTION BOOKLE - LOW ENVIRONMENTAL - IMPACT REHABILITATION - ARCò - Società Cooperativa



WAKEMAKE



ROME



2015



TOR VERGATA UNIVERSITY
WAKEMAKE ASSOCIATION



PRACTICAL

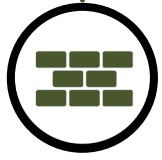

RECYCLED WOOD



A workshop for students of engineering-architecture which took place in the outside areas of the Tor Vergata University (Rome). It consisted of self-building of outdoor furniture, recycling unused materials from the construction site of the unfinished Calatrava's Sports City project, abandoned for 5 years. ARCò coordinated and supervised the work of the 24 student participants who were selected through a call for Students Cultural Activities. The aim of the workshop was to transform a space untapped by the students in a liveable and shareable one. The promotion of a certain way of doing architecture, sustainable and participatory, was pursued by self-constructing the objects with recycled materials.



ORDINE ARCHITETTI TRAPANI



TRAPANI



2015



ORDINE DEGLI ARCHITETTI



PRACTICAL/THEORETICAL

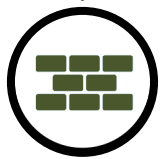

PISE' + STRAW BALES WALLS



Composizione | Estrazione | Filtrare | Testare

LA TERRA | STEP 1.4

LA TERRA A PISÈ È UN CEMENTO NATURALE

Ghiaia +	sabbia +	limo +	argilla +	acqua
0-20%	40-60%	20-35%	15-25%	

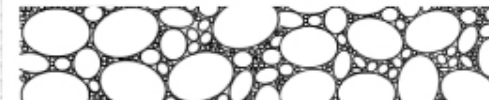

ELASTICITÀ: capacità a deformarsi senza rompersi.
COMPRESSIBILITÀ: capacità a densificarsi sotto compressione.
COESIONE: presenza di argilla di buona qualità che lega gli elementi tra di loro.
GRANULOMETRIA: presenza ottimale di tutti gli elementi di dimensione diverse che si organizzano tra di loro senza lasciare vuoti.

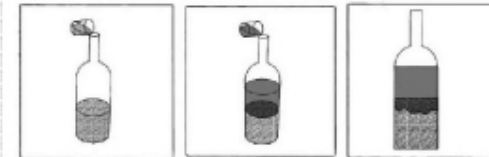

TEST DI SEDIMENTAZIONE - GRANULOMETRIA

1. Riempire 1/3 del contenitore col terreno
2. Segnare con un pennarello il limite superiore del terreno
3. Aggiungere un po' d'acqua
4. Mescolare e lasciare depositare 10
5. La sabbia che si deposita sul fondo del bicchiere rappresenta la proporzione presente nel terreno.
6. Attendere un'ora e la proporzione rimanente è argilla

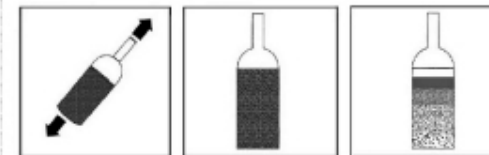

A series of lectures at the Architects Register of Trapani, dealing with the issues of construction with pisè and straw, involving theoretical knowledge and demonstrative practical workshop with the creation of portions of masonry.



IL MURO | STEP 2.5

Basamento | Struttura | Intonaco

Raggiunta l'altezza desiderata con le balle di paglia, coprire con un doppio cordolo in legno come quello appoggiato sullo zoccolo e riempito di argilla espansa. Eventualmente anche di ghiaia o paglia.



Riprendere le corde ed unirle tirandole leggermente.

Ogni 3 metri il muro si dovrebbe abbassare di circa 10/15 cm grazie ai trandi ben tesi.

Dopo 6 settimane dall'appoggio dal tetto di possono essere attestamenti dal 95-96%.

A questo punto il muro si è stabilizzato alla sua massima compressione.

Una muratura in paglia portante può reggere fino a 25 volte il peso di un tetto di pietra.



IL MURO | STEP 2.6

Basamento | Struttura | Intonaco

L'intonacatura si attacca meglio sulla parte di taglio rispetto quella di piego della balla, e avviene in quattro fasi successive:



- Intonaco con molta paglia e poca argilla e sabbia per riempire i buchi più grandi in modo da aver in imposte alleggerite che in alcuni punti può raggiungere anche i 10 cm e livellare così il muro e gli interspazi tra le balle di paglia.

- Intonaco con paglia argilla sabbia in giuste proporzioni per creare uno strato omogeneo su tutta la superficie del muro, cominciando dal basso e procedendo verso l'alto.

Questo strato può raggiungere i 5 cm ma non superati in una sola mano, altrimenti rischia di non restare attaccato alle balle di paglia.

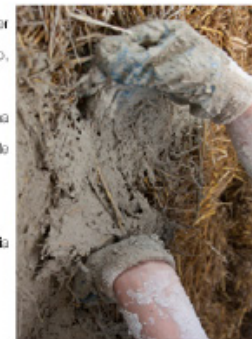

- Intonaco di rifinitura con la tecnica desiderata: con paglia sminuzzata, tadelakt, calce ecc. di pochi mm.

- eventuale colore ulteriore.

ARCOTIPO 3



TURIN



2013



IED - MASTER IN ARCHITETTURA SOSTENIBILE



PRACTICAL/THEORETICAL

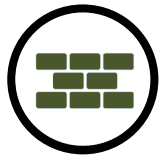

PLASTIC BOTTLE WALL

The workshop take place for the third year in the IED (European Institute of Design), as part of the Professional Master course in Sustainable Architecture, which ARCò coordinated together with Arch. Riccardo Balbo. The one month workshop consisted first of a theoretical part, dealing with the Urban Design of the Waterfront of Jounieh, Lebanon. Then, of a practical part during which a prototype was built in self-construction by the students to test the constructive techniques previously elaborated. The prototype, named ARCOTIPO 3, was realized in the Miraorti Area in Turin, using recycled plastic bottles and pallets to create outdoor furniture and structures to provide shade to the urban farmers.





PAESAGGI STRAORDINARI



LOCATE DI TRIULZI (MI)



2013



MASTER PAESAGGI STRAORDINARI + NABA - NUOVA ACCADEMIA DELLE ARTI MILANO AND POLITECNICO DI MILANO



PRACTICAL/THEORETICAL



RECYCLED WOOD



The week-long workshop concerned the design of a potting shed for the public allotments of the city of Locate di Triulzi. The design criteria were the sustainability of the materials, the process and the flexibility of use. After the design, the participants built a prototype of the selected project that was placed in the orchards.

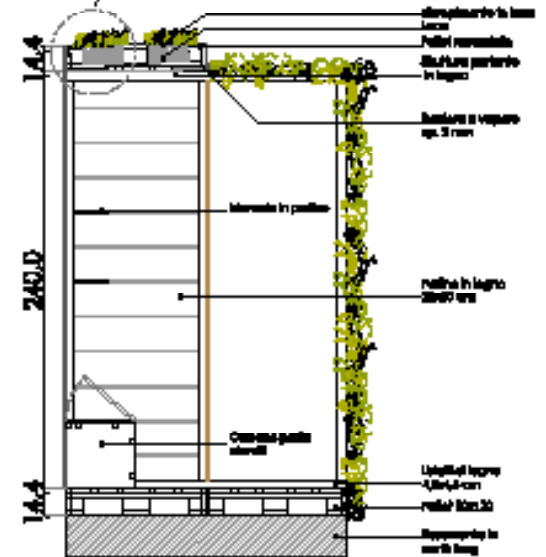
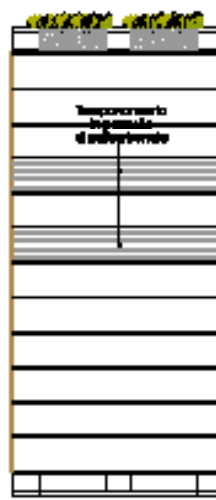
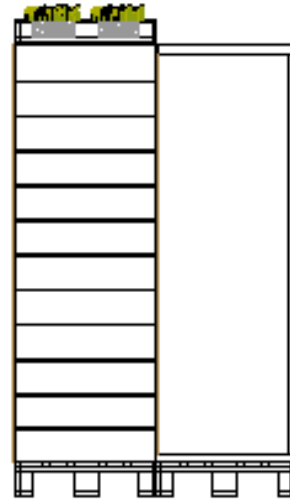
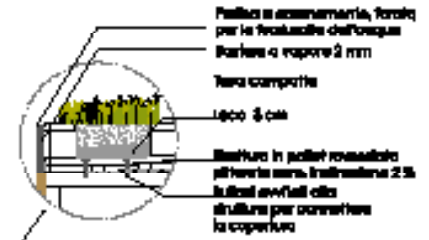
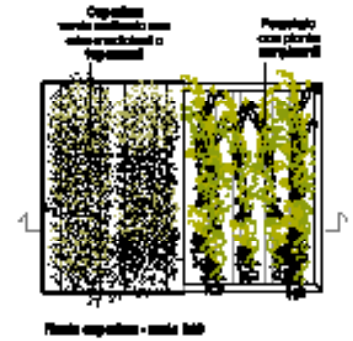
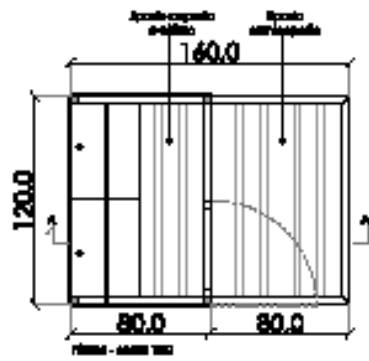

TAM TAM



LODI (MI)



2013



TAM TAM SCHOOL + GE.CO.



PRACTICAL

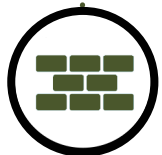

RECYCLED MATERIALS



The workshop consisted in designing a space for free exchange market in Lodi. Students were asked to design a piece of furniture made with recycled material. Temporarily used objects and material were the scenario of a one-day-event in which people met to exchange used clothes and accessories. Students themselves constructed the whole space in one morning.

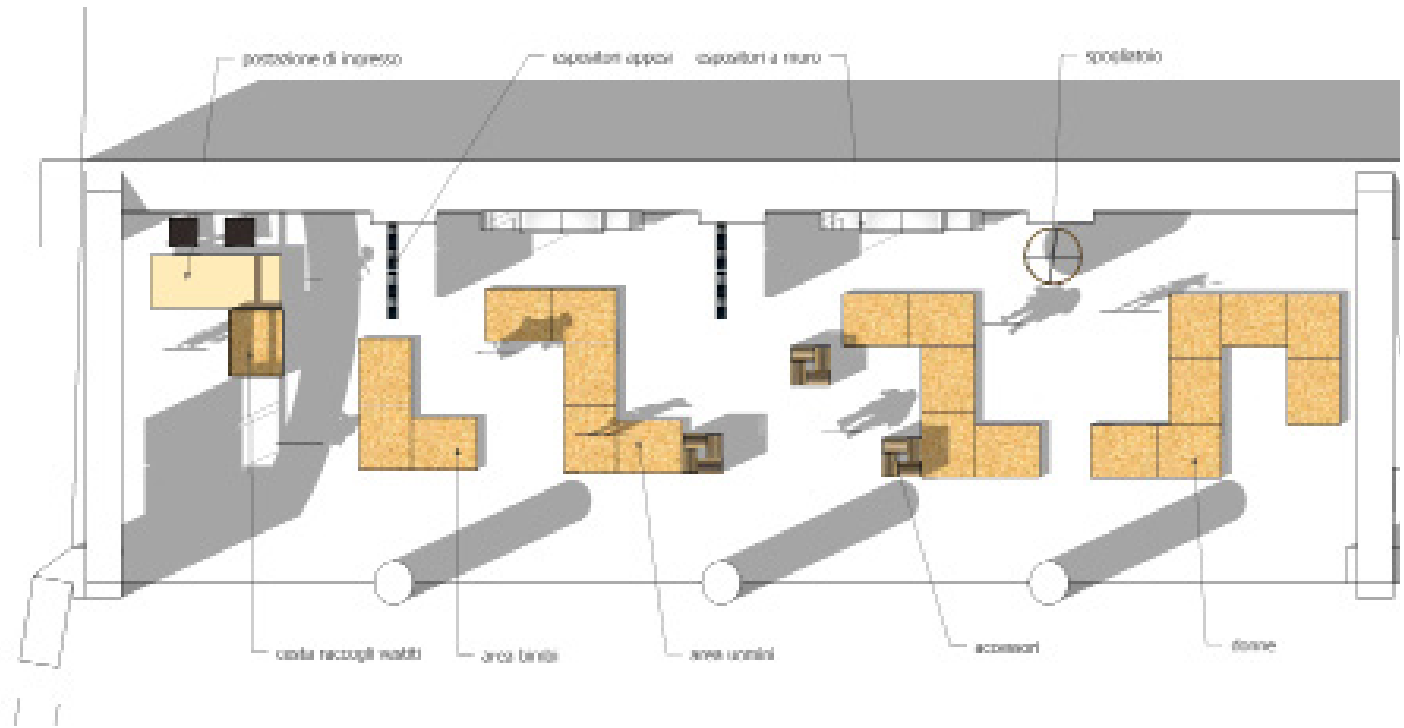

PARKING DAY



PAVIA



2012



UNIVERSITY OF PAVIA



PRACTICAL

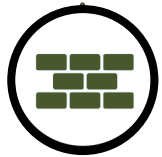

RECYCLED MATERIALS



The subject of the workshop was to think of possible alternative uses of a parking space. Students were lead to think at a parking area as a small size public space for people to gather, rest or play. The prototype was realized by the students and displayed in a public exhibition in Piazza Castello in Milan.



ARCOTIPO 2



TURIN



2012



IED - MASTER IN SUSTAINABLE ARCHITECTURE



PRACTICAL/THEORETICAL

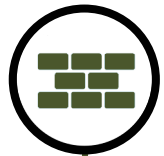

PLASTIC BOTTLE WALL + STRAW BALES WALLS



The workshop was developed in the frame of the “Master in sustainable architecture” that saw for the second time ARCò as co-coordinator together with Architect Riccardo Balbo. The prototype, named ARCOTIPO was realized on Michelotti park, in auto-construction by the master students with the support of local professionals. It consisted of small constructions realized in straw with the Nebraska technique and walls of recycled plastic bottles and clay.

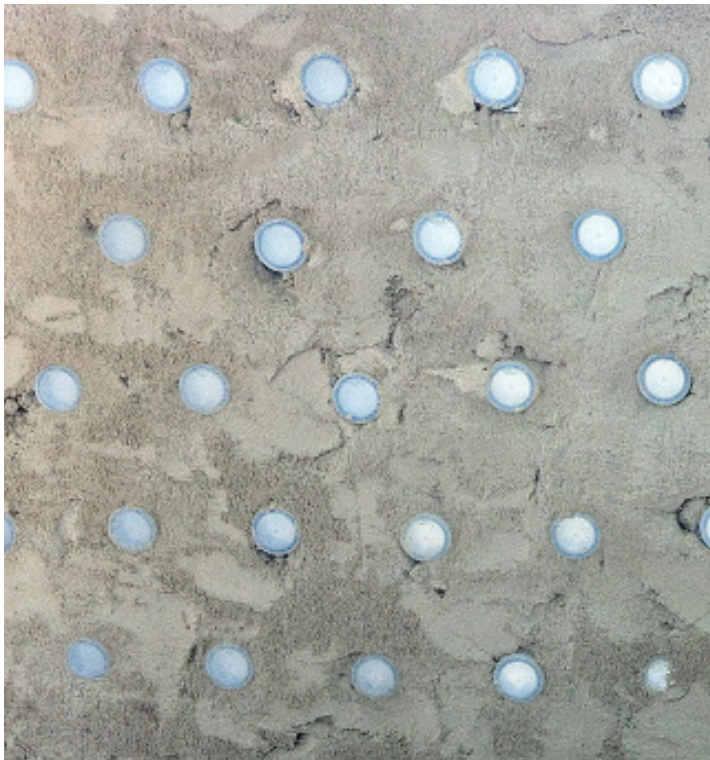

ARCOTIPO 1



TURIN



2011



IED - MASTER IN SUSTAINABLE ARCHITECTURE



PRACTICAL/THEORETICAL

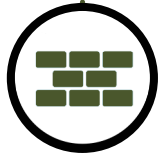

EARTHSHIP + EARTHBAGS



The workshop was developed in the frame of the “Master in sustainable architecture” in which ARCò was co-coordinator together with Architect Riccardo Balbo. The workshop took place during a month and consisted firstly of a theoretical part, during which the students developed the project for a school in the Gaza Strip, following the indications of the functional program and the specific locations suggested by the local authorities. Finally, a practical part started, with the realization of a prototype in which to test the constructive techniques previously envisioned: recycled tyres filled with soil, earth-bags, green roof. The prototype, an earthship named ARCOTIPO was realized in Michelotti park in Turin, with self-construction technique by the master students with the support of local professionals.



MODULO



ROME



2012



INARCH - ISTITUTO NAZIONALE DI ARCHITETTURA



PRACTICAL/THEORETICAL

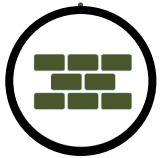

CONCRETE



The workshop, in the frame of the Master Course “Expert designer in emerging technologies”, concerned the design of a house module and the realization of a prototype in partnership with ITALCEMENTI.

Students were led to think about standard solutions for the construction of buildings to be realized in emergency context or post disaster situations. The designed structures should display specific characteristics: easy to build, easy to transport, quick to build.



keyplan

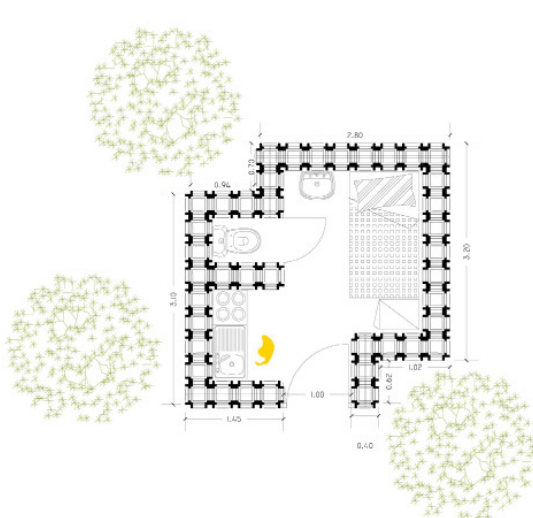
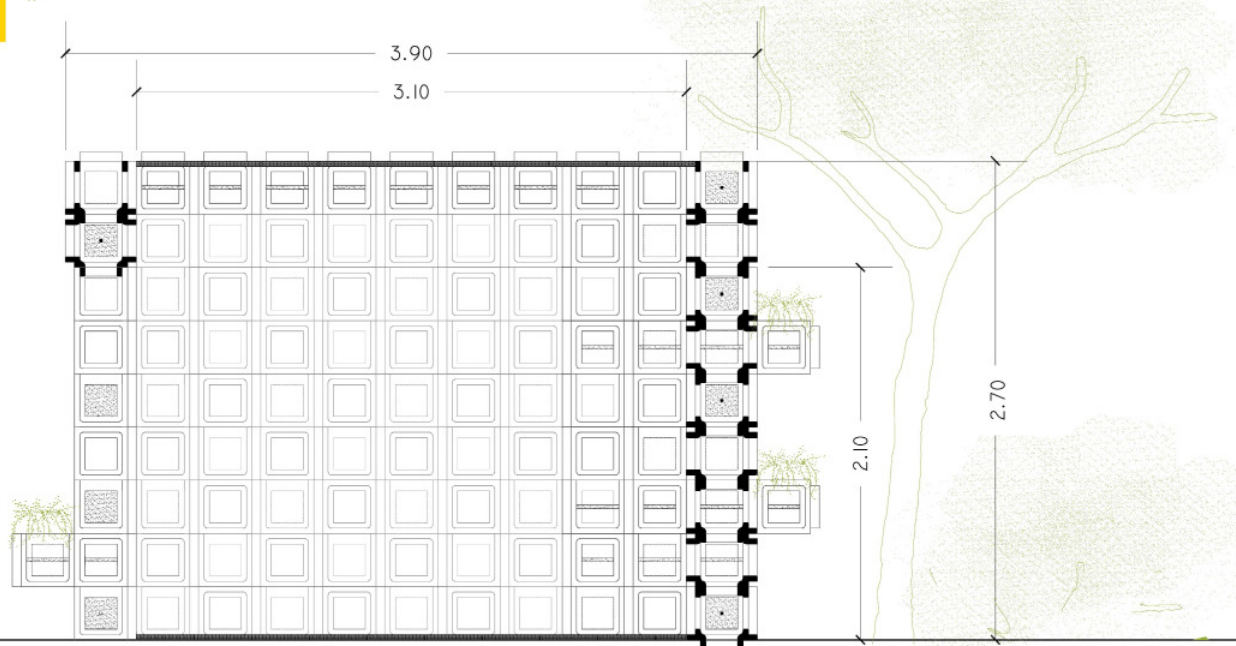

PIANTA MODULO SINGOLO

SCALA 1:50

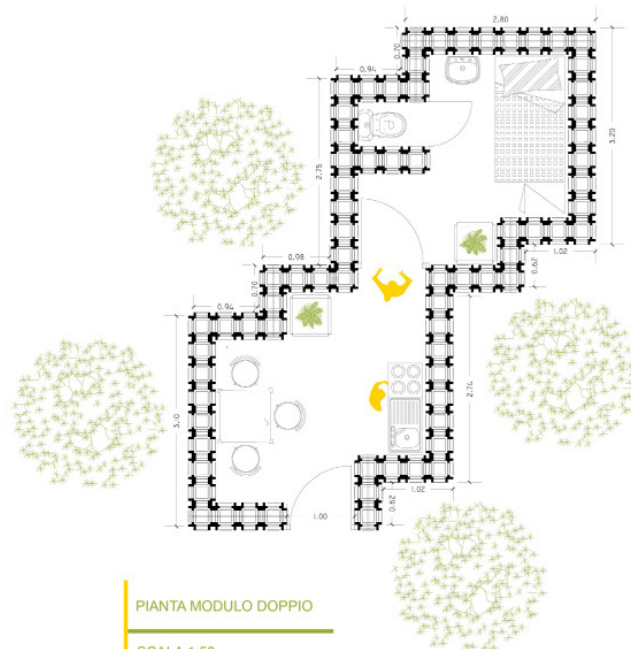

PIANTA MODULO DOPPIO

SCALA 1:50

ECOWEEK



JERUSALEM



2012



ECOWEEK



THEORETICAL



The workshop started with the description of several examples of sustainable auto-construction architectures and public spaces. Sustainable building techniques, innovative uses of low cost and recycled materials, specific needs, participation proceedings, education of inhabitants in self-construction techniques as the target topics. Participants were involved in the analysis and creation of a proposal for a self-construction project for a park in the village of Al Walajeh, in the outskirts of Jerusalem. The exercise focused on the particular situation of the village of Al Walajeh, and the consequences of the Israeli-Palestinian conflict on its public space, on the possibility to build a collective place for the local community and integrate it with the existing and newly-planned surroundings.



Master plan

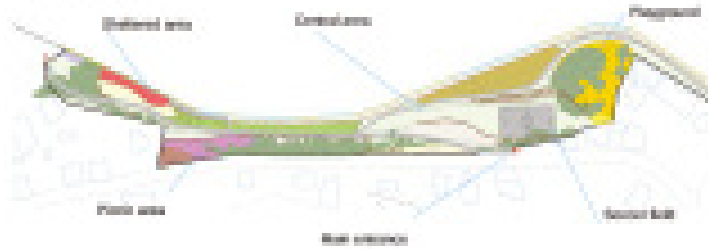

01



CONCEPT
 The building is designed as a series of interconnected volumes that respond to the site's topography and the need for a multi-functional space. The design is inspired by the concept of a 'living building' that evolves and adapts to its environment.

PROGRAM
 The building is designed to accommodate a variety of activities, including exhibitions, performances, and community events. The design is flexible and allows for future expansion and adaptation.



SECTIONAL VIEW
 The building is designed to provide a series of interconnected volumes that respond to the site's topography and the need for a multi-functional space. The design is inspired by the concept of a 'living building' that evolves and adapts to its environment.

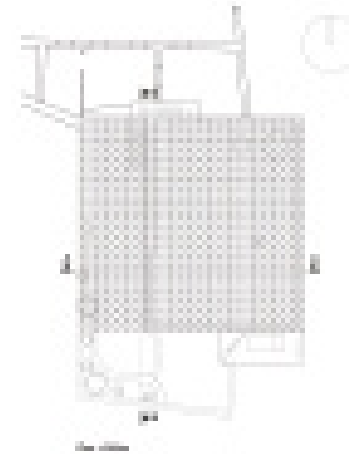
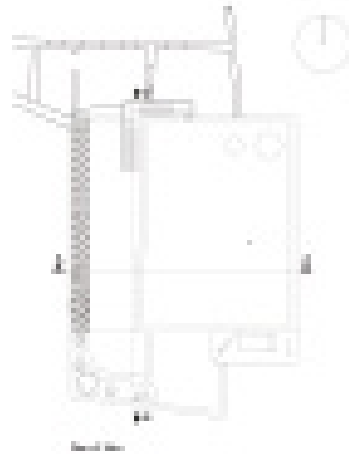

SECTIONAL VIEW
 The building is designed to provide a series of interconnected volumes that respond to the site's topography and the need for a multi-functional space. The design is inspired by the concept of a 'living building' that evolves and adapts to its environment.

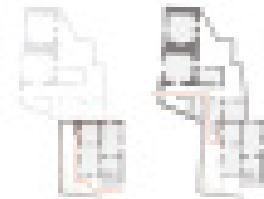

SECTIONAL VIEW
 The building is designed to provide a series of interconnected volumes that respond to the site's topography and the need for a multi-functional space. The design is inspired by the concept of a 'living building' that evolves and adapts to its environment.

SECTIONAL VIEW
 The building is designed to provide a series of interconnected volumes that respond to the site's topography and the need for a multi-functional space. The design is inspired by the concept of a 'living building' that evolves and adapts to its environment.

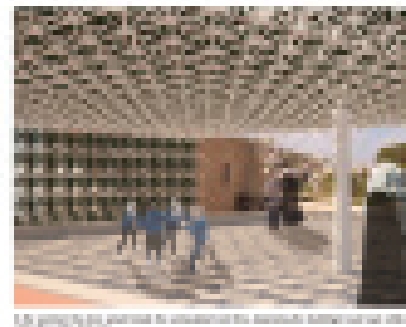
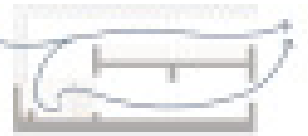

ECOWEEK



MILAN



2011



ECOWEEK



THEORETICAL



The starting point of the work proposed to the student was the case of the Gypsy Camps in Italy. Students were led to find solutions to provide temporary houses for Gypsies using materials such as earthbags, tires and straw bales. The purpose was, as usual in the philosophy of the studio, to build innovative solutions through practical research experience.

project's technique: straw bales



project's technique: earthbags

SOLE

vernicello fotovoltaico
 acquasole
 pannello fotovoltaico

ACQUA

raccolta di acque piovane

ARIA

ventilazione notturna
 tetto verde
 pareti in legno

TERRA

isolamento a strati termici di 20 cm
 pannelli a scorta
 muri a strati termici di 20 cm
 spessi di roccia



DETTAGLIO 2, SCALA 1:10

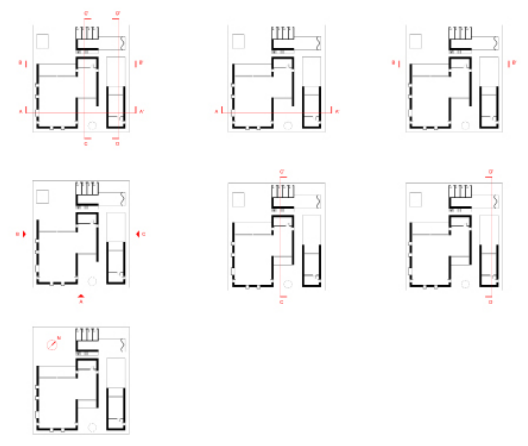
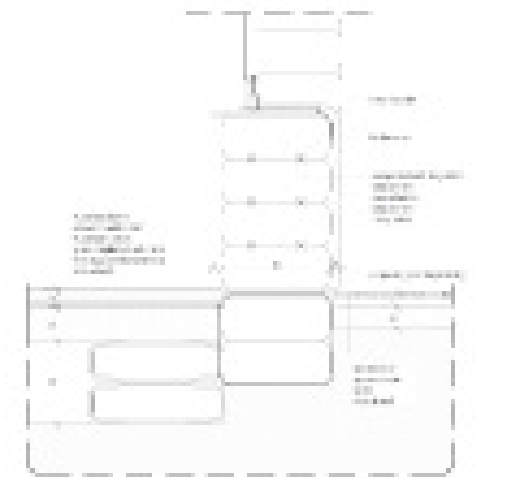

P U B B L I C A T I O N S
& A W A R D S





PUBBLICAZIONI



books



magazine



multimedia

2016 • SUMMA+ n.153
Donn S.A.,
Buenos Aires, 2016



2016 • ARKETIPO n.105
New Business Media srl,
Milano, 2015



2016 • ARQUITECTURA VIVA
n. 185
Editorial Arquitectura Viva SL,
Madrid, 2016



2016 • LE ARCHITETTURE
ECOSOLIDALI n.31
Hachette fascicoli srl
Milano, 2016



2016 • MODULO n.401
Be-Ma Editrice,
Milano, 2016



2015 • ARCHITETTURA E CITTA'
n.10
Di Baio Editore,
Milano, 2015



2015 • AIT n.5
AIT Editoriale,
Leinfelden-Echterdingen, 2015



2015 • OASE n.95
Oase Foundation,
Rotterdam, 2015



2015 • LOTUS n.158 ott
Editoriale Lotus,
Milano, 2015



2015 • CASABELLA n.854
Arnoldo Mondadori Editore S.p.A.,
Milano, 2015



2015



PLEA 2015

Architettura in (r)evolution
Bologna, 2015



2013



PROGETTARE n.05 ott

Tecniche nuove S.p.A.
Milano, 2013



2015



KLASS SCHULE feb.

ifa Gallery Berlin,
Berlin 2015



2013



BOUNDARIES n.10

International architectural magazine,
Rome, 2013

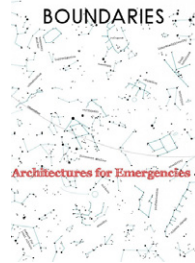

2014



GREEN n.31 ott

Domus China,
Beijing, 2014



2013



SUMMA+ n.130

Donn S.A.,
Buenos Aires, 2013



2014



OTT AGONO n.268 mar

Compositori Comunicazione s.r.l.
Milano, 2014



2013



ARCHITETTURA E CITTÀ n.08

Di Baio Editore,
Milano, 2013



2014



EKOLOGIC n.37 mar

France métropolitaine
Paris, 2014



2013



GREEN n.04 lug

Domus China,
Beijing, 2013



2013



BOUNDARIES n. 08
International architectural magazine,
Rome, 2013



2013



LE QUATTRO STAGIONI
catalogo della 13 mostra
internazionale di architettura,
Mondadori Electa spa, Milano,
2013



2013



ZEPPELIN n.111 feb
Q-Group Project and Zeppelin
Association, Bucharest, 2013



2013



**TEORIE E
SPERIMENTALISMO
PROGETTUALE PER LA
RICERCA IN TECNOLOGIA
DELL'ARCHITETTURA**
QC, Firenze, 2013



2012



IOARCH n. 46 gen/feb
Editore Font Srl,
Milano, 2012



2013



**GIOVANI ARCHITETTI
ITALIANI**
video documentario edito da
GiArch and IN/ARCH, 2013



2012



ddb speciale cersaie
DDW srl,
Milano, 2012



2012



PROGETTARE a.6, n.3
Tecniche nuove S.p.A. ,
Milano, 2012



2013



NEEDS,
architecture in developing countries.
edito da Spataro S.,
Lettera Ventidue, Siracusa, 2013



2012



**IL GIORNALE
DELL'ARCHITETTURA**
n. 106



2012



A10 n. 57 sett/ott
A10 publisher, Amsterdam, 2012



2012



PALESTINIANS,
A photographic journey through stories of lives and cooperation.
Edito da Tibollo A., pubblicato da Consulate General of Italy, office of development cooperation, Jerusalem, 2012.



2012



ABITARE n.519 feb
RCS Mediagroup, Milan, 2012



2012



UNDER 40
Premio "rassegna lombarda di architettura Under 40"
Il Sole 24 ORE S.p.A., Milano, 2012

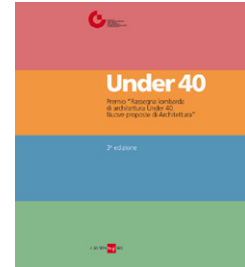

2012



CASABELLA n. 809
Arnoldo Mondadori Editore S.p.A., Milan, 2012



2012



GOLD MEDAL FOR ITALIAN ARCHITECTURE
Edited by La Triennale di Milano, Editrice Compositori, Milano, 2012.



2012



OFARCH n.120
Design Diffusion World, Milan, 2012



2012



GIARCH - PROGETTI DI GIOVANI ARCHITETTI ITALIANI
Edito da Bucci A. Marsaglia V., Vol. III, Utet Scienze Tecniche, Turin 2012



2012



SUSTAINABLE CONSTRUCTION
2011/2012
terzo premio holcim, Edito da Schwarz E., Fineprint AG, Stallikon, 2012.



2012



ITALIARCHITETTURA
premio fondazione Renzo Piano
Edited by Prestinenzza Puglisi L. Piano R., Utet Scienze Tecniche, Torino 2011.



2011



BOUNDARIES n. 02

International architectural magazine, Rome, 2011

BOUNDARIES



2011



EME3

2011



2011



AV n.125

Arquitectura Viva, Madrid 2011.



2010



IL GIORNALE DELL'ARCHITETTURA n. 11-12



2011



DOMUS AUREA n.04

Edizioni Rendi, Fratta Terme, 2011

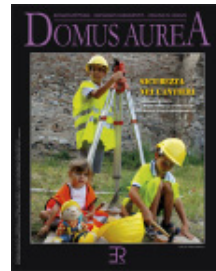

2011



ARCHITETTURA E CITTÀ n.06

Di Baio Editore, Milano, 2011



2011



AV ATLAS

Arquitecturas del siglo XXI, África y Oriente Medio, Edited by Fernandez Galiano L., Atlas, Arquitectura Viva S.L. & Fundación BBVA, Madrid 2011.

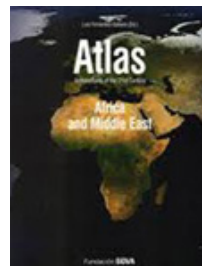



PREMI

2016

RI.U.SO. 05 Rigenerazione Urbana Sostenibile, indetto dal Consiglio Nazionale degli Architetti Pianificatori Paesaggisti e Conservatori
Terzo classificato



2012

Global Holcim Awards finalisti dei Global Holcim Awards, con il progetto Rinnovamento sostenibile di una scuola primaria nel campo beduino Wadi Abu Hindi, Territori Occupati Palestinesi.



2015

Architect Sans Frontiere International Award 2015, 'Learning South of North' menzione di onore.



2012

Medaglia d'Oro alla Architettura Italiana IV edizione
Finalista menzione d'onore architettura ed emergenze



2011

HOLCIM AWARDS

Medaglia d'argento per la sezione
"Africa and Middle East"



2011

PREMIO EME3 CITY AWARDS

Menzione speciale per i progetti
"Schools in the desert. Bio-climatic
architecture for education in the
Bedouin communities in Palestine"



2011

PREMIO FONDAZIONE RENZO PIANO

Secondo posto per il progetto "la
scuola nel deserto".



2011

PREMIO SPECIALE SELINUNTE

Per il contributo al miglioramento
dell'ambiente.



Contatti

ARCò - Architettura e Cooperazione
Società Cooperativa
Via Friuli, 26/A
20135 - Milano, Italy
info@ar-co.org
www.ar-co.org
tel. +39.02.87280580
fax. +39.02.87280580

